

प्रापण विभाग, केंद्रीय कार्यालय, मुंबई
PROCUREMENT DEPARTMENT, CENTRAL OFFICE, MUMBAI
1st floor, 239, Union Bank Bhawan, Vidhan Bhawan Marg,
Nariman Point, Mumbai - 400021
Phone No: 022-45653726

Ref:CO:PROC: 52 :2026

Date:08.04.2026

Corrigendum - 1 to tender document Reference No.
PROC:0337:2026 dated 18.03.2026 issued for the RFP for
empanelment of OEMs for procurement of physical security products
on a Pan-India basis

With reference to the tender document published on 18.03.2026, the important dates related to the tender document are revised as follows:

- Original date of Issuance of tender document: 18.03.2026.
- Last date for submission of tender document (as per original schedule): 13.04.2026 upto 3.00 pm
- Revised last Date for Submission of tender document: 04.05.2026 up to 3:00 PM
- Date of Opening of tender document: 04.05.2026 at 3:30 PM

Any further modifications to the RFP, if necessary, will be published exclusively through an Addendum/Corrigendum on the Bank's official website <https://www.unionbankofindia.bank.in> and on the Government e-Procurement portal <https://www.eprocure.gov.in>.

Note: All other terms and conditions of the RFP published on 18.03.2026 remain unchanged.

सहायक महाप्रबंधक
(प्रापण विभाग)

RFP FOR EMPANELMENT OF OEMS FOR PROCUREMENT OF PHYSICAL SECURITY PRODUCTS IN BRANCHES ON PAN INDIA BASIS

RFP REFERENCE NO: PROC:0337:2026

DATED: 18.03.2026

Union Bank of India, Procurement Department
1st floor, 239, Union Bank Bhawan, Vidhan Bhawan Marg,
Nariman Point, Mumbai - 400021
Website: www.unionbankofindia.bank.in

Name of OEM: _____

Address of OEM: _____

Date of Issue: 18.03.2026

Date of Pre bid Meeting: 01.04.2026 at 11.30 AM

Last date of Submission: 13.04.2026 upto 3.00 PM

Date of Opening of Technical bid: 13.04.2026, 3.30 PM

DISCLAIMER

1. The information contained in this Request for Proposal (RFP) is provided to the OEM(s) on the terms and conditions set out in this RFP document. The RFP document contains statements derived from information that is believed to be true and reliable at the date obtained but does not purport to provide all the information that may be necessary or desirable to enable an intending contracting party to determine whether or not to enter into a contract or arrangement with Bank in relation to the provision of services.
2. The purpose of this RFP is to provide the OEM(s) with information to assist the formulation of their proposals. This RFP does not claim to contain all the information each OEM may require. Each OEM should conduct their own investigations and analysis and should check the accuracy, reliability and completeness of the information in this RFP and where necessary obtain independent advice. Union Bank of India makes no representation or warranty and shall incur no liability under any law, statute, rules or regulations as to the accuracy, reliability or completeness of this RFP. Union Bank of India may in its absolute discretion, but without being under any obligation to do so, update, amend or supplement the information in this RFP. The RFP document is not a recommendation, offer or invitation to enter into a contract, agreement or any other arrangement, in respect of the supply of Physical Security Product's in Bank's branches on pan India basis. The provision of the services is subject to empanelment and selection of OEM through the process of tender and appropriate documentation being agreed between the Bank and successful OEMs as identified by the Bank. No contractual obligation whatsoever shall arise from the RFP process unless and until a formal contract is signed and executed by duly authorized officers of Union Bank of India with the OEM.
3. This RFP is not exhaustive in describing the functions, activities, responsibilities and services for which OEM will be responsible. The OEM(s), by participating in this process for empanelment, implicitly confirm that if any functions, activities, responsibilities or services which are either not specifically described in this RFP or specifically described but has to undergo suitable changes/modifications due to regulatory/statutory changes and are termed necessary by the Bank for the proper performance of the Contract, such functions, activities, responsibilities or services (with applicable changes, if any) will be deemed to be implied by and included within the scope of services under this RFP and OEM response to the same extent and in the same manner as if specifically described in this RFP and OEM's response.
4. No reimbursement of cost of any type or on any account will be paid to persons or entities submitting their proposals.

Abbreviations

Abbreviations	Description
Bank/ UBI/ Union Bank	Union Bank of India
BFSI	Banking, Financial Services and Insurance
BG	Bank Guarantee
EMD	Earnest Money Deposit
LD	Liquidated Damages
NDA	Non-Disclosure Agreement
Proposal/ Bid	The OEM's written reply or submission in response to this RFP.
PO	Purchase Order
PSB	Public Sector Bank
PSU	Public Sector Undertaking
PBG	Performance Bank Guarantee
RFP	Request For Proposal (this document) in its entirety, inclusive of any addenda that may be issued by the Bank.
SLA	Service Level Agreement
TDS	Tax Deducted at Source

GENERAL INSTRUCTIONS TO BIDDERS:

1. Bidders must submit their complete proposal in hard copy, duly sealed and signed, strictly as per the instructions provided in this RFP. No email or online submission will be accepted.
2. Request for proposal (RFP) is can be downloaded from Bank's website www.unionbankofindia.bank.in & govt. portal www.eprocure.gov.in from 06:00 pm on 18/03/2026 to 3.00 pm on 13/04/2026
3. All physical bids must be deposited only in the designated Drop Box located at: Union Bank of India, Ground Floor, Central Office, 239, Vidhan Bhavan Marg, Nariman Point, Mumbai - 400021.
4. Bidders are responsible for ensuring that their sealed proposal reaches the Drop Box before the specified deadline. Late submissions, regardless of the reason, will not be considered.
5. Bidders must ensure that all required documents, annexures, and enclosures are included. Incomplete or unsigned submissions may lead to rejection.
6. Interested bidders are requested to send all correspondence related to this RFP to the following email IDs:

Email:procurement@unionbankofindia.bank.in

Contact number:Phone - 022 -45653726

Bidders must include the following details in their communication to enable the Bank to issue clarifications, if required:

- Name of the Bidder / Organization
- Name and designation of the contact person
- Registered address
- Contact number and official email ID
- RFP reference number and subject line

Start Date and Time of issue of RFP/ Document Download	18-03-2026 Time:- 06.00 PM
Last date and time for submission of query on email	31.03.2026 Time:- 05.00 PM
Date of Pre-bid Meeting	Pre bid meeting will be held online through Online Meeting Platform Microsoft Teams on 01.04.2026 at 11:30 AM.
Last date and time for submission of Bidding Document	13.04.2026 Time:- 03.00 PM
Date and Time of Technical Bid Opening	13.04.2026 Time:- 03.30 PM
Downloading RFP	RFP can be downloaded from www.unionbankofindia.bank.in or Government tender portal www.eprocure.gov.in . However, the OEMs are required to submit the tender fee in the form of a demand draft along with the proposal.
Place of opening of Bids/ Prebid Meeting	Union Bank of India, Procurement Department, 1 st Floor, Central Office, 239, Vidhan Bhavan Marg, Nariman Point, Mumbai - 400 021.
Address & Contact Numbers	As above.
Earnest Money Deposit (EMD)	Nil.
Tender fee (Non-Refundable)	Rs. 3000/- (INR Three Thousand Only) by Demand Draft in favour of "Union Bank of India" and payable at Mumbai from any of the nationalized/ schedule commercial bank (Non-Refundable).
Exemption	OEMs registered in relevant field with NSIC/ Udyam Registration as MSE are eligible for availing relaxations/ exemptions as per Govt. policy in vogue. However, MSE OEMs need to provide valid NSIC/ MSE certificate clearly mentioning that they are registered with NSIC under single point registration scheme or Udyam Registration.
Performance Guarantee	Rs. 45,00,000/- (Rupees ten lakhs only) by way of bank guarantee valid in the format mentioned in Annexure K.
Contact details	Interested OEMs are requested to send the email to: procurement@unionbankofindia.bank.in containing below mentioned information, so that in case of any clarification same may be issued: Name of company, contact person, Mailing address with Pin Code, Telephone No., Mobile No., email address etc.
Validity	Proposals & other submissions should remain valid for 180 days after the submission date.
Submissions	OEMs must submit an original empanelment form to: Address: Union Bank of India, Union Bank Bhavan, Procurement Department, 1 st Floor, 239, Vidhan Bhavan Marg, Nariman Point, Mumbai - 400 021.
Last date for submissions	Proposals must be submitted not later than the following date and time: 13-04-2026 by 3:00 PM. Proposals received after the deadline will be rejected.

Note: Bids once submitted will be treated as final and no further correspondence will be entertained on this. No bid will be modified after submission of bids.

TABLE OF CONTENTS

1.	INTRODUCTION	6
2.	INTEGRITY PACT (IP)	6
3.	OBJECTIVES OF THE RFP	6
4.	DEFINITIONS	6
5.	INVITATION OF TENDER BIDS	7
6.	BASIC ELIGIBILITY CRITERIA	7
7.	SPECIAL CONDITIONS OF CONTRACT	16
8.	SCOPE OF RFP	24
9.	COST OF BIDDING	24
10.	LANGUAGE OF BID	24
11.	INSTRUCTION FOR BID SUBMISSION	24
12.	TAXES AND DUTIES	30
13.	REJECTION OF BID	30
14.	MODIFICATION AND WITHDRAWALS OF BID	31
15.	RFP RESPONSE	31
16.	PAYMENT TERMS	31
17.	LIQUIDATED DAMAGES (LD)	31
18.	AUTHORIZED SIGNATORY	31
19.	CONFIDENTIALITY	32
20.	INDEMNITY	32
21.	NON-TRANSFERABLE OFFER	33
22.	RESPONSIBILITY FOR COMPLETENESS	33
23.	MINIMUM WAGES	33
24.	FORCE MAJEURE	33
25.	EXIT CLAUSE	34
26.	TERMINATION OF CONTRACT	34
27.	GOVERNING LAW & JURISDICTION	34
28.	AUDIT	35
29.	PREBID MEETING	35
30.	CONFLICT OF INTEREST	35
31.	RFP OWNERSHIP	36
32.	TENDER/RFP CANCELLATION	36
33.	PUBLICITY	36
34.	ARBITRATION	36
35.	DISPUTE RESOLUTION & JURISDICTION	36
36.	INSTRUCTIONS, TERMS & CONDITIONS	36
37.	SUBMISSION OF BIDS	38
38.	ANNEXURE:	39
	ANNEXURE A: Letter of Acceptance	39
	ANNEXURE B: Proposal for Empanelment of OEM Suppliers	41
	ANNEXURE C: Compliance to RFP Terms & Conditions	44
	ANNEXURE D: Format for Financial Summary	46
	ANNEXURE E: List of Projects (Completed and On-going)	47
	ANNEXURE F: Anti-Collusion Certificate	48
	ANNEXURE G: Bid Security Declaration	49
	ANNEXURE H: Declaration for Compliance	50
	ANNEXURE I: Confidentiality / Non-Disclosure Agreement	51
	ANNEXURE J: Empanelment Certificate	56
	ANNEXURE K: Format for Performance Bank Guarantee	57
	ANNEXURE L: Pre-Contract Integrity Pact	59
	ANNEXURE M: Bid Query Format	63
	ANNEXURE N: Certificate of Waiver for MSE Firms	64
	ANNEXURE O: Indemnity bond format	65
	ANNEXURE P: Undertaking for Testing	66

1. INTRODUCTION

Union Bank of India, a Public Sector Bank has its Central Office (Registered Office) at 239, Vidhan Bhavan Marg, Union Bank Bhavan, Nariman Point, Mumbai - 400021, having Procurement Department at Central Office Mumbai. The Bank is a leading, innovative Scheduled commercial Bank, with a proactive approach to address the changing needs of the society. This has resulted in a wide gamut of products and services, made available to its valuable customers in catering to the smallest of their needs with 8,490 Branches including foreign branches, 22 Zonal Offices and 140 Regional Offices which are spread across various geographic locations. No of Branches/Offices/Regional Offices/Zonal Offices and other offices will increase over a period of time.

2. INTEGRITY PACT (IP)

OEM supplier, only those who commit themselves to Integrity Pact (IP) with the Bank, would be considered competent to participate in the bidding process. In other words, entering into this pact would be the preliminary qualification. The Bid without OEM's Commitment to IP shall be rejected summarily.

IP shall cover all phases of contract i.e. from the stage of Notice Inviting Tenders (NIT)/ Request for Proposal (RFP) till the conclusion of the contract i.e. final payment or the duration of warrantee/guarantee.

Format of IP is attached as Annexure L for strict compliance.

The following Independent External Monitors (IEMs) have been appointed by the Bank, who will review independently and objectively, whether and to what extent parties have complied with their obligation under the pact.

a) Shri. Jagdish Prasad Meena, IAS (Retd.), e-mail- meenajp@gmail.com

b) Shri. Arvinda kumar, IPS (Retd.), e-mail- arvindak@gmail.com

Integrity Pact will be considered as part of RFP and same to be submitted duly signed with technical Bid. Non-submission of IP along with technical Bid will lead to rejection.

3. OBJECTIVES OF THE RFP

Union Bank of India invites proposals from BIS licensed OEMs for empanelment for procurement of physical security products in branches on pan India basis.

The empanelment process would be carried out through open tender wherein technical bids would be called from eligible OEMs. Based on the technical bids and technical evaluation of the bidder/OEMs, they will be empanelled with our Bank for a period of three years.

4. DEFINITIONS

Union Bank of India (hereinafter called as "Bank" or "the Bank") invites proposals/Bids from OEMs (hereinafter referred to as "Respondent" or "OEM" or "Vendor") for empanelment of OEMs for procurement of physical security products in branches on pan India basis for a period of three years to the Bank.

4.1 'Bank' means unless excluded by and repugnant context or the meaning thereof, shall mean 'Union Bank of India', which has invited bids under this Request for Proposal and shall be deemed to include its successors and permitted assigns.

4.2 'RFP' means this Request for Proposal prepared by Union Bank of India for the empanelment/selection of OEM.

4.3 "Agency", "Firm", "Company", "OEM", "Applicant", "Bidder", "Proposer", "Vendor" means any entity or associations of persons who submit their proposals to the Bank in accordance with this RFP.

- 4.4 “Authorized Signatory” means the person authorized by the company’s Board/Managing Director/Director through a proper authorization to represent the company for purpose of this bid submission and finalization.
- 4.5 ‘Proposal’ means that technical proposal including any documents submitted by the OEM as per the formats prescribed in the RFP.
- 4.6 ‘Rate Contract’ means contract between the Bank and empaneled vendors to supply physical security products pan India, on rates finalized after tender process.

5. INVITATION OF TENDER BIDS

This RFP is an invitation for OEM’s responses. OEMs are expected to examine all instructions, forms, terms, specifications, and other information in the RFP document. Failure to furnish any information required by the RFP document or to submit a bid not substantially responsive to the RFP document in every respect will be at the OEM’s risk and shall result in the rejection of its bid. The procedure and terms & conditions for submission of bid are enumerated in this RFP.

All offers of the OEMs shall be unconditional and once accepted whether with or without modifications by the Bank shall be binding between the Bank and such OEM.

Any type of formation of consortium, sub-contracting and assignment/ Joint assignments will not be allowed/considered. Such proposals will be disqualified.

6. BASIC ELIGIBILITY CRITERIA

Only those OEMs fulfilling the following criteria should respond to the RFP. Offers received from the OEMs who do not fulfil any of the following eligibility criteria or not submitting any of the documents are liable to be rejected.

OEMs will be entitled to the exemptions/ relaxations under relevant provisions in the MSME Act 2006 and subsequent government notifications in vogue, if otherwise eligible. Such OEMs claiming exemptions/ relaxations, have to submit the necessary documentation in support of their claim.

Sr. No.	Parameters	Requirements	Required Documents	Yes/ No
a.	Average turnover volume	<p>(i) The proposer OEM bidding for major physical security products should have total average annual sales turnover from Physical security products, not less than Rs. 15.00 Crore in the last three years, i.e. from year 2022-23 to 2024-25.</p> <p>(ii) The proposer OEM bidding only for FRFC should have total average annual sales turnover from Physical security products, not less than Rs. 1.00 Crore in the last three years, i.e. from year 2022-23 to 2024-25.</p> <p>Audited Balance sheets & Profit & Loss Statements of mentioned period are to be submitted. The turnover from the business of only Physical Security Products would be considered</p>	Copy of the *Audited Balance Sheet along with Profit and Loss statement for FY 2022-23, 2023-24 & 2024-25.	

		for this purpose. Bifurcation of the same shall be reflected in the Audited balance sheet or a certificate with UDIN from CA mentioning the turnover from business of Physical Security Products shall be provided.	
b.	Profit in the previous financial years	The OEM should not have incurred operating loss in the last three years, i.e. from FY 2022-23 to 2024-25.	
c.	Registered Companies	The OEM should have been registered under the Companies Act at least 10 years earlier from the date of tender opening.	Certificate of incorporation. Copy of the Partnership deed/Bye Laws/ Certificate of Incorporation issued by Registrar of Companies along with Memorandum & Articles of Association and full address of the registered office. GST certificate; PAN card; EPFO/ESIC Registration
d.	OEMs	The firm requesting empanelment should be the Original Physical Security Manufacturer (OEM) of the product for which he is seeking empanelment i.e. Cash and/or Gold Safes, Strong Room Doors, Modular Panel Vault (MPV), Locker Units and Fire-Resistant Filing Cabinets (FRFC)	Self-Declaration to be submitted.
e.	In-house manufacturing process	<p>Process of pre-treatment of MS Steel Sheet, it's Crosshatch test and preparation of TDR (Barrier) Material for manufacturing Cash & Gold Safes, Vault Doors, Locker Units, Modular Panel Vault (MPV), Fire Resistant Filing Cabinets (FRFC) and making their locks & keys should be done in-house by OEM to qualify for the empanelment for the respective product.</p> <p>If any OEM does not have in-house facility of pre-treatment and is getting it done at facility of other agency, then arrangement for facilitating the visit of bank officials during technical evaluation and anytime thereafter, has to be made by the OEM bidder.</p>	Self-Declaration to be submitted.

		Failure to facilitate such visit by OEM during technical evaluation shall render the bidder to be disqualified. Failure to facilitate such visit after empanelment at anytime including surprise visits shall render a monetary penalty on bidder as deemed fit but not more than Rs. 50000/- and/or cancellation of empanelment.		
f.	BIS License	The proposer OEM should have valid BIS licenses, for a. Cash and Gold Safes b. Strong Room Doors c. Locker Units d. Fire Resistant Filing Cabinets, e. Modular Panel Vault (MPV) Issued on or before the proposal opening date as mentioned in the RFP document. The proposer OEM should have valid BIS license for the product with respective class for which empanelment is being sought.	The list of OEMs posted/updated on the BIS website will be taken as the conclusive proof for the purpose of eligibility.	
g.	Network of offices/dealers	The proposer OEM should have at least one office/dealer in every State in India with exception of the Northeastern states. At least one office/dealer in Assam or in any of the other North-Eastern States shall be considered sufficient for the entire NE region.	Attach list of offices/dealers with address along with landline numbers and email address. Absence of any of these details or wrong details shall make the proposal ineligible.	
h.	Empanelment with other PSBs	The proposer OEM should have been in the panel of approved suppliers for Safes, Strong Room doors, Locker Units and FRFCs in minimum two public sector banks other than Union Bank of India, for last three years including current year, and should not have been blacklisted by any PSB in last three years.	Empanelment letters to be submitted. Self-Declaration for not blacklisted by any PSB to be submitted.	

i.	Reference Sites	Furnish name, address telephone numbers of and the offices of at least two public sector banks, with whom proposer OEM is empaneled at present for the supply of Safes, Vault Doors, Locker Units and FRFCs and supplied these products in the last three years.	As per format provided.	
----	------------------------	--	-------------------------	--

In addition to Basic Eligibility Criteria, following would be specific eligibility Criteria for specific Physical security Product. A proposer OEM would need to meet both the Criteria.

(6.A) SPECIFIC ELIGIBILITY CRITERIA FOR STRONG ROOM DOOR

Sr. No.	Parameters	Requirements	Required documents	Yes/ No
a.	License	The Product must be Licensed by BIS and every Vault Door being supplied would mandatorily have BIS label.	BIS issued license to be submitted.	
b.	Minimum period business of Vault Door manufacturing	Minimum two years	Work orders to be attached.	
c.	Vault Doors Manufactured	The proposer (OEM) should have manufactured not less than 100 TRTL Vault Doors in the past three years, i.e. from the year 2022-23 to 2024-25.	Copies of the form 3CA, form 3CD & CA certificate along with extract of relevant portion of tax audit report which has quantitative details of vault doors manufactured and certified by a registered tax auditor under section 44AB of Income Tax Act 1961 and Income Tax Rule 6G(2) should be attached as proof document.	

(6.B) SPECIFIC ELIGIBILITY CRITERIA FOR CASH SAFE

Sr. No.	Parameters	Requirements	Required documents	Yes/ No
a.	License	The Product must be licensed by BIS and every Cash & Gold Safe being supplied would mandatorily have BIS label	BIS issued license to be submitted.	
b.	No. of years required in Safe manufacturing business.	Minimum two years	Work orders to be attached.	

c.	Cash / Gold Safe Manufactured	The proposer (OEM) should have manufactured not less than 300 Cash and/or Gold Safes in the past three years, i.e. from the year 22-23 to 24-25.	Copies of the form 3CA, form 3CD & CA certificate along with extract of relevant portion of tax audit report which has quantitative details of Safes manufactured and certified by a registered tax auditor under section 44AB of Income Tax Act 1961 and Income Tax Rule 6G(2) should be attached as proof document.
----	--------------------------------------	--	---

d.	Testing of Safe by the Bank	<p>The bidder OEMs should give its written consent for the testing of Safe (Cash & Gold) as under:</p> <p>a) Bank reserves the right to get ONE safe (Cash/Gold) subjected to destructive testing at any of the BIS accredited / approved test house for each 100 pieces supplied by each OEM. The cost of replacing the safe to be tested, its transportation to test house and of the testing will be fully borne by the supplier OEM.</p> <p>b) In case any safe, supplied by the OEM under current empanelment, is successfully cut or broke open by burglars, the Bank would subject to test the same safe at any BIS accredited / approved test house irrespective of number of safes supplied by such OEM. If this safe fails in the destructive test also, the OEM will have to make good entire loss suffered by the Bank including the value of items & cash kept inside the safe and the cost of replacement of safe.</p> <p>c) In both the cases, if safe fails in destructive testing, Bank reserves the right to cancel the empanelment and also debar the supplier OEM from participating in future empanelment process for a period as decided by the Bank. Bank may also consider blacklisting such OEM.</p>	Written consent to be submitted.	
----	------------------------------------	---	----------------------------------	--

(6.C) SPECIFIC ELIGIBILITY CRITERIA FOR FIRE RESISTING FILING CABINET (FRFC)

Sr. No.	Parameters	Requirements	Required documents	Yes/ No
a.	License	The Product must be licensed by BIS and every FRFC being supplied would mandatorily have BIS label	BIS issued license to be submitted.	
b.	No. of years required in FRFC manufacturing business.	Minimum two years	Work orders to be attached.	
c.	FRFC Manufactured	The proposer (OEM) should have manufactured not less than 300 FRFCs in the past three years, i.e. from the year 22-23 to 24-25.	Copies of the form 3CA, form 3CD & CA certificate along with extract of relevant portion of tax audit report which has quantitative details of FRFCs manufactured and certified by a registered tax auditor under section 44AB of Income Tax Act 1961 and Income Tax Rule 6G(2) should be attached as proof document.	
d.	Testing of FRFC by the Bank	The bidder OEMs should give its written consent for the testing of FRFC as under: a) Bank reserves the right to get ONE FRFC subjected to destructive testing at any of the BIS accredited/ approved test house for each 100 pieces supplied by each OEM. The cost of replacing the FRFC to be tested, its transportation to test house and of the testing will be fully borne by the supplier OEM. b) In case, FRFC fails in destructive testing, Bank reserves the right to cancel the empanelment and also debar the supplier OEM from participating in future empanelment process for a period as decided by the Bank.	Written consent to be submitted.	

(6.D) SPECIFIC ELIGIBILITY CRITERIA FOR SDLC (OPEN TYPE)

Sr. No.	Parameters	Requirements	Required Documents	Yes/ No
---------	------------	--------------	--------------------	---------

a.	License	The product must be licensed by BIS and every SDLC being	BIS issued license to be submitted.	
		supplied would mandatorily have BIS label		
b.	No. of years required in SDLC manufacturing business	Minimum two years	Work orders to be attached.	
c.	SDLC manufactured	The proposer (OEM) should have manufactured not less than 300 SDLCs in the past three years, i.e. from the year 22-23 to 24-25.	Copies of the form 3CA, form 3CD & CA certificate along with extract of relevant portion of tax audit report which has quantitative details of Safes manufactured and certified by a registered Tax Auditor under Section 44AB of the Income Tax Act 1961 should be attached as proof documents.	

(6.E) SPECIFIC ELIGIBILITY CRITERIA FOR SAFE-CUM-SAFE DEPOSIT LOCKERS CABINETS

Sr. No	Parameters	Requirements	Required Documents	Yes/ No
a.	License	The outer safe body must be licensed by BIS and every Safe-cum-safe deposit locker being supplied should have a BIS label equivalent to the classification & rating of outer safe body and every Safe Deposit Locker inside the safe should be manufactured as per IS 5244:2020, along with its amendment no.1 of Oct 2022.	BIS issued license to be submitted.	
b.	No. of years required in Safe-cum-Safe Deposit Lockers Cabinets manufacturing business	Minimum two years	Work orders to be attached.	
c.	Safe-cum-Safe Deposit Lockers cabinets manufactured	The proposer (OEM) should have manufactured not less than 100 Safe-cum-Safe Deposit Lockers cabinets in the past three years, i.e. from the year 2022-23 to 2024-25.	Copies of the form 3CA, form 3CD & CA certificate along with extract of relevant portion of tax audit report which has quantitative details of Safes manufactured and certified by a registered Tax Auditor under Section 44AB of the Income Tax Act 1961 should be attached as	

			proof documents.
--	--	--	------------------

6(F) Specific Eligibility Criteria for Modular Panel Vault (MPV)

Sr. No	Parameters	Requirements	Required Documents	Yes/ No
a.	License	The proposer (OEM) must be licensed by BIS and all panels being supplied would mandatorily have BIS label/embossed.	BIS issued license for manufacturing panels for MPV to be attached.	
b.	No. of years required in MVP manufacturing business.	Minimum two Years	Work orders to be attached.	
c.	MPV Manufactured	The proposer (OEM vendor) should have manufactured not less than 300 Panels of MPV since the date of BIS License.	Copies of the form 3CA, form 3CD & CA certificate along with extract of relevant portion of tax audit report which has quantitative details of Safes manufactured and Certified by a registered Tax Auditor under Section 44AB of the Income Tax Act 1961 should be attached as proof documents.	
d.	Testing of MPV by the Bank	<p>The proposer (OEM vendor) should give its written consent to Bank as under:-</p> <p>a) to test three randomly selected panels out of every 1000 such panels manufactured for the Bank before or after joining them as per vault construction. Such testing would be done totally at vendor's cost strictly as per BIS testing norms, at any one of the labs chosen by the Bank. In case any panel of the supplied MPV is cut or broken successfully by burglars, testing will be carried out of cut panel or any other panel of the same MPV immediately, even without waiting for supply target of 1000 panels.</p> <p>b) If this MPV panel fails in</p>	Written consent to be submitted.	

		<p>the destructive test also, the OEM will have to make good entire loss suffered by the Bank including the value of items & cash/pledged gold kept inside the MPV and the cost of replacement of MPV.</p> <p>c) In both the cases, if panel of MPV fails in destructive testing, Bank reserves the right to cancel the empanelment and also debar the supplier OEM from participating in future empanelment process for a period as decided by the Bank.</p>		
--	--	---	--	--

7. SPECIAL CONDITIONS OF CONTRACT

7.1. TECHNICAL SPECIFICATIONS FOR STRONG ROOM (VAULT) DOORS

- A. Only BIS certified(labeled) Strong Room Doors of class 'B', 'A', 'AA' & 'AAA' as per specifications given in IS 11188(Part 1):2021 shall be procured by the Bank.
- B. Class-wise minimum dimensions and other technical specifications for the Strong Room doors should be as follows:

(All dimensions in millimeters)

Sr. No.	Particulars		Strong Room Main Doors				Emergency doors			
			Class 'B'	Class 'A'	Class 'AA'	Class 'AAA'	Class 'B'	Class 'A'	Class 'AA'	Class 'AAA'
a)	Door Types									
b)	Overall Dimension of Strong Room (Vault) doors	Height H	2300	2350	2350	2450	1200	1200	1200	1300
		Max Min	2100	2100	2100	2250	900	900	900	1000
		Width W	1400	1450	1450	1550	1250	1250	1250	1350
		Max Min	1250	1250	1250	1350	1100	1100	1100	1200
c)	Inside Dimension of or Clear opening when door shutters are swung open at 180°	Height H	1950	1950	1950	1950	600	600	600	600
		Min								
		Width W	900	900	900	900	750	750	750	750
		Min								
d)	Number of locks		2	2	2	2	2	2	2	2
e)	No. of shooting bolts on hinge side		Min	6	6	6	3	3	3	2
f)	No. of shooting bolts on opposite side		Min	6	6	6	3	3	3	2
g)	No. of shooting bolts on top		Min	-	2	2	-	-	-	1

h)	No. of shooting bolts at bottom	Min	-	2	2	2	-	-	-	1
i)	Cross sectional area per shooting bolt, Minimum (mm ²) with 25 mm as minimum Nominal dimension in any direction		1134	1963	1963	3318	1134	1963	1963	3318
J)	Depth of engagement of shooting bolts	Min	15	15	15	20	15	15	15	20

- C. A ventilating grill gate should be hinged to the Strong Room door frame to open inward. The ventilating grill gate should be made of mild steel angles, plates or channels with mild steel rods welded in a rigid frame. An unpickable dual control locking device capable of being operated from both the sides of the door shall be fitted on the grill gate.
- D. The shooting bolt mechanism of the Strong Room door shall be controlled by two 8 lever (Minimum) high-precision dual-control unpickable special-key locks. The locks should be provided with stainless steel keys in duplicate.
- E. Locking mechanism, shooting bolt mechanism and door construction shall be such as to facilitate providing and fixing a time lock at any later date.
- F. The Strong Room doors should have been certified by the Bureau of Indian Standards (BIS) as Class 'B' or Class 'A' or Class 'AA' or Class 'AAA', and shall bear a metallic BIS Label, which inter alia should contain the following information:
- a) Manufacturer's/ Brand Name
 - b) Class & Rating of Strong Room (Vault) door, i.e.,
Class 'B'; TRTL 30 - FR 30 or
Class 'A'; TRTL 60 or
Class 'AA'; TRTL 120 or
Class 'AAA' TRTL 180
 - c) Serial Number of the door
 - d) Year of manufacturing of Strong Room door
 - e) The 'ISI' mark of BIS (along with the Standards No. of BIS)
 - f) The CML Number allotted by the BIS to the Manufacturer.

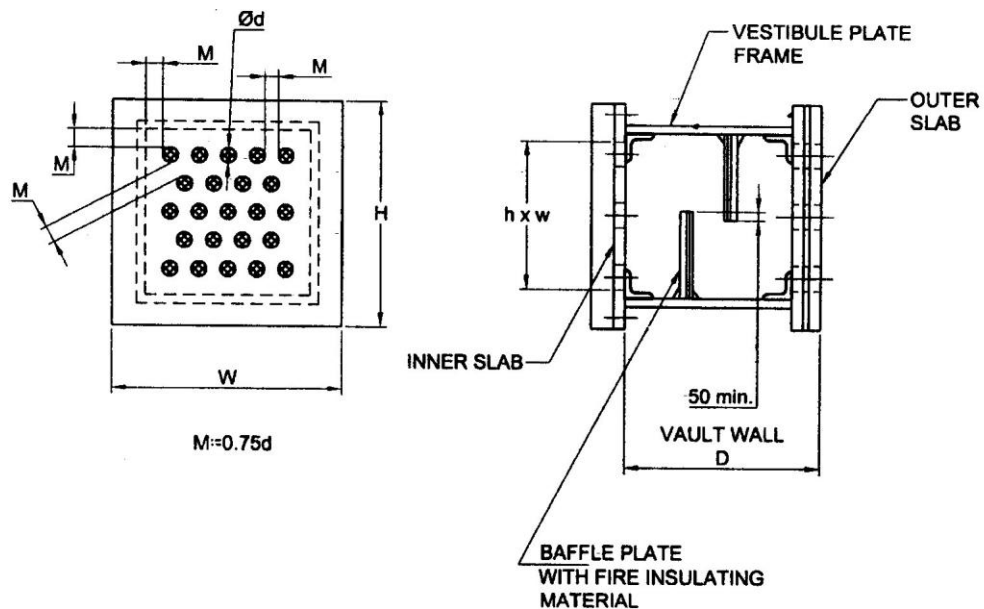

All dimensions in millimetres.

7.2. TECHNICAL SPECIFICATIONS FOR AIR VENTILATORS

A. Air Ventilator of class 'B', 'A', 'AA' & 'AAA' as per BIS specifications given in IS 14387: 2021 shall be procured by the Bank.

B. The class-wise minimum dimensions and other technical specifications for the Air Ventilator should be as follows:

(All dimensions in millimeters)

Sr. No.	Particulars	Strong Room Air Ventilator				
		Class 'B'	Class 'A'	Class 'AA'	Class 'AAA'	
1)	Vault/ Strong Room class					
2)	Overall dimensions of Air Ventilator	Height H Min	410	410	410	410
		Width W Min	410	410	410	410
		Depth D Min	300	300	450	600
3)	Inside Dimension of Air Ventilator	Height h Min	300 ± 25			
		Width w Min	300 ± 25			
4)	Thickness of outer slab	–	22	40	50	60
5)	Thickness of oxyacetylene torch	Min	5	30	40	50
	resisting material in outer slab					
6)	Thickness of inner slab/ plate	Min	10	40	50	60
7)	Thickness of torch and drill resisting (TDR) matrix in inner slab	–	–	30	40	50
8)	Thickness of vestibule frame	Min	5			
9)	Thickness of fire insulating material	–	5			
10)	Burglary resistance	Min	20	45	90	120

7.3. TECHNICAL SPECIFICATIONS FOR CASH/GOLD SAFE

A. Only BIS-certified (labeled) Safes of either Class 'BB' or Class 'A' or 'AA' as per BIS specifications given in IS 550 (Part 1):2022 will be procured by the Bank. The Safes should

bear a metallic BIS Label, which, inter alia, should contain the following information:

- a) Manufacturers Name.
- b) Class & Rating of Safe i.e., Class 'BB'; TRTL 15x6 or Class 'A'; TRTL 30x6 or Class 'AA';TRTL 60x6.
- c) Year of manufacturing of Safe & Serial Number of the Safe.
- d) The ISI mark of BIS (along with the Standards No., i.e., IS 550 (Part 1): 2022.
- e) The CML Number allotted by the BIS to the Manufacturer.

B. The Safes (Class 'BB', 'A' & 'AA') should conform to the following minimum specifications:

- a) **Size of Safe:** As per the requirement of bank confirming to IS 550(Part 1):2022.
- b) **Shooting Bolts:** For better security against brutal attack on the Safe, irrespective of its class, the Safe should have at least four shooting bolts on the hinge side, four bolts on the side opposite to hinge side and two bolts each on top and bottom sides. Only on the hinge side of the door, instead of four shooting bolts a single continuous bolt of sliding or fixed nature making engagement into the body for at least two-third of the internal height is also acceptable.
- c) **Key Locks:** For Class 'BB', 'A' & 'AA' Safes, the Safe door should have at least two key locks and both the key locks should be of dual-control type. The main lock shall have minimum of 8 levers. No two locks shall have the same combination.
- d) **Keys:** Each lock shall be provided with duplicates of main and auxiliary keys. The keys shall be mutually non-interchangeable i.e., no lock shall open by other than its own specific keys.
- e) **Automatic Relocking Device:** An automatic relocking device one for each key lock shall be fitted in the door which being always on guard shall come into operation if a lock is dislodged by explosives or any other means.

C. The Gold safe shall be provided with a minimum of 16 lockable drawers inside.

7.4. TECHNICAL SPECIFICATIONS FOR SAFE DEPOSIT LOCKER CABINETS (OPEN TYPE)

Only BIS certified (labeled) Safe Deposit Locker Cabinets (SDLCs) as per IS 5244:2020 of the following types and specifications shall be procured by the Bank: -

- a) Type 1 - Containing 75 lockers
- b) Type 1A - Containing 90 lockers
- c) Type 2 - Containing 52 lockers
- d) Type 2A - Containing 51 lockers
- e) Type 3 - Containing 32 lockers
- f) Type 4 - Any other configuration

Safe Deposit Locker Cabinet Type 1 (75 Lockers)

Lockers		Minimum Inside Measurements (mm)		
Size	No.	High	Wide	Deep
A	66	115	149	470
2A	6	115	329	470

4A	3	266	329	470
----	---	-----	-----	-----

Cabinet Size: 2000 mm highx1100 mm wide x 575 mm deep (outside) with Tolerance: \pm 25 mm.

Safe Deposit Locker Cabinet Type 1A (90 Lockers)

Lockers		Minimum Inside Measurements (mm)		
Size	No	High	Wide	Deep
A	90	115	149	470

Cabinet Size: 2000 mm highx1100 mm wide x 575 mm deep (outside) with Tolerance: \pm 25 mm.

Safe Deposit Locker Cabinet Type 2 (52 Lockers)

Lockers		Minimum Inside Measurements (mm)		
Size	No	High	Wide	Deep
B	48	148	184	470
2B	2	148	401	470
4B	2	314	401	470

Cabinet Size: 2000 mm highx1100 mm wide x 575 mm deep (outside) with Tolerance: \pm 25 mm.

Safe Deposit Locker Cabinet Type 2A (51 Lockers)

Lockers		Minimum Inside Measurements (mm)		
Size	No	High	Wide	Deep
B	46	148	184	470
2B	2	148	401	470
4B	2	314	401	470
2B1	1	314	184	470

Cabinet Size: 2000 mm highx1100 mm wide x 575 mm deep (outside) with Tolerance: \pm 25 mm.

Safe Deposit Locker Cabinet Type 3 (32 Lockers)

Lockers		Minimum Inside Measurements (mm)		
Size	No	High	Wide	Deep
D	28	178	238	470
2D	2	178	506	470
4D	2	394	506	470

Cabinet Size: 2000 mm highx1100 mm wide x 575 mm deep (outside) with Tolerance: \pm 25 mm.

- B. Lockers shall be secured with first class unpickable lever dual control key-lock. They shall be self-locking so that custodian does not have to re-lock the locker with his (custodian's) key after the lessee has locked it.
- C. The mechanism of the lock shall be such that the lessee shall not be able to withdraw his key unless the locker has been re-locked fully. Once the lessee has locked the locker, the same cannot be opened unless the custodian turns in his key to take off his control.
- D. No key of one lock shall apply to any other lock except its own for lessee. The lessee's as well as the custodian's keys shall be made of stainless steel.
- E. The lock and shutter arrangement shall be such that the main bolt of the lock projecting into locker or the locking hole, as the case may be, shall have sufficient protection against tampering with crowbar or other hand tools.

F. The SDLCs shall bear a metallic BIS label bearing BIS Standard Mark with IS Standard Number, Manufacturer's name/trademark, Type of the Locker Cabinet, year of manufacture, Serial Number of the SDLC, CML Number allotted by BIS to the manufacturer.

7.5. TECHNICAL SPECIFICATIONS FOR SAFE-CUM-SAFE DEPOSIT LOCKER CABINET

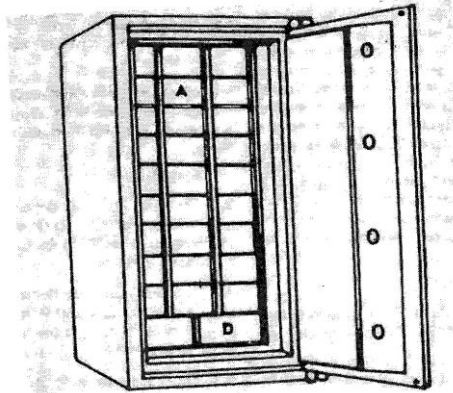

A. Only Safe-cum-Safe Deposit Locker Cabinets with BIS certified (labeled) Safe body of class 'A' / 'AA' as per IS 550 (Part 1):2022 and with following specification for the safe body and the safe deposit lockers inside, shall be procured by the Bank: -

Safe-cum-Safe Deposit Lockers having 29 lockers

Safe Size (Height in mm) Minimum	Lockers		Minimum internal dimensions of Lockers (In mm)		
	Size	No. of Lockers	Height	Width	Depth
1340	A	27	115	149	400
	D	2	165	238	400

Safe-cum-Safe Deposit Lockers having 56 lockers

Safe Size (Height in mm) Minimum	Lockers		Minimum internal dimensions of Lockers (In mm)		
	Size	No. of Lockers	Height	Width	Depth
1860	A	56	115	149	492

Safe-cum-Safe Deposit Lockers having 46 lockers

Safe Size (Height in mm) Minimum	Lockers		Minimum internal dimensions of Lockers (In mm)		
	Size	No. of Lockers	Height	Width	Depth
1860	A	40	115	149	492
	2A	4	115	329	492
	4A	2	266	329	492

Safe-cum-Safe Deposit Lockers having 36 lockers

Safe Size (Height in mm) Minimum	Lockers		Minimum internal dimensions of Lockers (In mm)		
	Size	No. of Lockers	Height	Width	Depth

1860	A	24	115	149	492
	2A	8	115	329	492
	4A'	2	266	329	492
	4A	2	253	329	492

B. The Safe body shall be of Class 'A' / Class 'AA' as per IS 550 (Part 1):2022 and shall conform to the following minimum standards: -

- a) **Shooting Bolts:** For better security against brutal attack on the Safe body, the Safe body should have at least four shooting bolts on the hinge side, four bolts on the side opposite to hinge side and two bolts each on top and bottom sides. Only on the hinge side of the door, instead of four shooting bolts a single continuous bolt of sliding or fixed nature making engagement into the body for at least two-third of the internal height is also acceptable.
- b) **Key Locks:** The Safe door should have at least two key locks and both the key locks should be of dual-control type. The main lock shall have minimum of 8 levers. No two locks shall have the same combination.
- c) **Keys:** Each lock shall be provided with duplicates of main and auxiliary keys. The keys shall be mutually non-interchangeable i.e., no lock shall open by other than its own specific keys.
- d) **Automatic Relocking Device:** An automatic relocking device one for each key lock shall be fitted in the door which being always on guard shall come into operation if a lock is dislodged by explosives or any other means.

C. The safe body shall bear a metallic label fixed on the inner face of Safe-cum-Safe Deposit Locker's door indicating Manufacturer's Name, Class & Rating of Safe body i.e., Class 'A'; TRTL 30x6/ Class 'AA', TRTL 60x6 year of manufacturing, ISI mark with the Standards No., i.e., IS 550 (Part 1): 2022, Serial number of the Safe body and the CML Number allotted by the BIS to the Manufacturer.

7.6. TECHNICAL SPECIFICATIONS FOR FIRE RESISTING FILING CABINETS (FRFCs)

A. Only BIS certified (labeled) Fire Resistant Filing cabinets (FRFCs) as per specifications given in IS 14561:2014 shall be procured by the Bank.

B. The FRFC shall be of standard vertical type with four drawers having fire resisting rating of not less than 120 minutes and manufactured as per BIS Standards IS 14561:2014.

C. The standard four-drawer FRFC shall have its dimensions not less than those stipulated below:

(In millimeters)		
Description (min.)	Over-all Dimensions	Internal Usable Space of Drawers
Height	1550	260
Width	500	370
Depth	770	600

D. The base of the bottom drawer should be at least 60 mm above floor level and the overall height of the FRFC, i.e., 1550 millimeters is inclusive of the pedestal.

E. Each drawer of the cabinet should be removable but should be fitted with a latch/ positive

stop to prevent inadvertent withdrawal and rebound. Such latch shall be lifted/unlocked by the pull of the handle or any other mechanism.

- F. Each drawer should have a handle made of non-corrosive material fixed in the front face of the drawer or with a built-in pulling mechanism.
- G. The drawers should not have sharp corners or edges so as to avoid injury or damage to clothing.
- H. The top drawer should be provided with dual control key lock having not less than six levers or pin cylinder lock having not less than six pins and with duplicate keys of stainless steel/nonferrous alloy. The locking mechanism should be such that when the top drawer is pushed in fully it actuates the locking mechanism to lock all other drawers simultaneously when they are in pushed-in position. At the time of locking the cabinet, if one of the drawers is not fully pushed-in, that drawer should remain unlocked and can be used; as soon as that drawer is pushed in fully, it should get locked automatically without further operation of the key by the user. Besides, isolation mechanism should also be provided to permit independent locking / use of other drawers. Such isolation mechanism provided on drawers should be manually operated.
- I. The keys should bear an identification number, which should not be the same as the serial number of the cabinet.
- J. The FRFC shall bear a metallic label fixed on inside surface of the top drawer of the cabinet such a way that it is visible when it is opened. The label should indicate Manufacturer's name or trademark, Classification of the cabinet, year of manufacture, Serial number of the FRFC, CML number allotted by BIS to the manufacturer and ISI mark i.e., IS 14561.

7.7 TECHNICAL SPECIFICATIONS FOR MODULAR PANEL VAULT

1. Bank shall procure Modular Panel Vault (MPV) consisting of only BIS certified (labeled) Modular Panels as per IS 17541:2021 of customized size as per requirement.
2. MPV can be of continuous design panel (full height of room) or Segmented design panel (Two or more segments for full height of room).
3. The wall panels can be fitted on site by welding or bolting or combination of both. In case of bolted design, the joining method shall be such that the bolts or counter sunk screws are not accessible or traceable when viewed externally or accessible from outside.
4. The wall panels to have provision for fitting vault main doors, vault emergency doors, air ventilators and cable entry.
5. MPV installation would consist of providing and installing in position BIS Labelled 'B' Class Modular panel Vault conforming to applicable IS along with 'B' Class Strong Room Door, Grill Gate, Air Ventilator, Exhaust fan & V-cage conforming to their respective IS.
6. The surface of the MPV including vault door and other fittings shall be painted or powder coated as specified in IS 17541:2021.
7. If the size of vault room necessitates supports in the form of beams and pillars, those shall be provided from the position which is not accessible from outside.
8. Modular panel shall be marked with metal plate/embossing showing classification, type, together with manufacturer's name, serial no, total numbers of panel in the set and year of manufacture shall be fixed on the inner face of one of the panel in such a way that it is visible from inside. An identification serial number in continuation shall also need to painted / punched / engraved.

8. SCOPE OF RFP

In order to ensure uniformity in quality, Bank has decided to carry out empanelment of BIS licensed OEMs of Physical Security Products, i.e. Cash & Gold Safes, Strong Room Doors, Safe Deposit Locker Cabinets, Safe cum Safe Deposit Locker Cabinets, Modular Panel Vault (MPV) and Fire Resisting Filling Cabinets (FRFCs).

The empanelment process would be carried out through open tender wherein technical bids would be called from eligible OEMs. Based on the technical bids and technical evaluation of the bidder OEMs, they will be empanelled with our Bank for a period of three years.

After empanelment, Pan India Rate Contract (RC) for commonly used physical security products will be carried out separately on GeM portal till the validity of empanelment by inviting price bids for each individual product, only from empanelled OEMs. Since GeM authorities have made the provision of Rate Contract in GeM portal very recently and if bank is unable to carry out the rate contract on GeM due to any reason, then bank may go for Rate Contract outside GeM by inviting price bids only from the empanelled OEMs.

The orders will be placed with selected L1 & L2 OEMs in the ratio of 70:30 if L2 OEMs agrees to match the price quoted by L1. In case L2 doesn't match the rates of L1, the offer to match the rates of L1 will be passed on to L3 & on so on.

Procurement will be done by Zonal / Regional Offices as and when required, through GeM, as per the Pan India rate contract.

Customized security products which are not readily available in GeM portal, would be procured through limited tender from the same empanelled OEMs outside GeM portal.

9. COST OF BIDDING

OEM shall bear all the costs associated with the preparation and submission of its bid and the bank, will in no case be responsible or liable for these costs, regardless of the conduct or outcome of the bidding process.

All costs and expenses [whether in terms of time or material or money] incurred by the OEM in any way associated with the development, preparation, and submission of responses, including but not limited to attendance at meetings, discussions, demonstrations, etc. and providing any additional information required by the Bank, will be borne entirely and exclusively by the OEM.

10. LANGUAGE OF BID

The language of the bid response and any communication with the Bank must be in written English only. Supporting documents provided with the tender response can be in another language so long as it is accompanied by an attested translation in English, in which case, for purpose of evaluation of the bids, the English translation will prevail.

11. INSTRUCTION FOR BID SUBMISSION

11.1 PREPARATION OF BID

- A. Proposals once submitted cannot be withdrawn by the OEM.
- B. Reputed OEM meeting the minimum qualifying criteria as on the date of RFP are

eligible to apply. OEM not meeting the necessary eligibility criteria will not be considered for further evaluations.

- C. The proposal should be put in single sealed envelope clearly marked “Response to RFP to empanelment of OEM suppliers for supply & installation of physical security products for branches in pan India” against <RFP Reference Number> and the wordings “DO NOT OPEN BEFORE <Date and Time> as mentioned in the “Important Dates & Details”.
- D. The outer envelope thus prepared should also indicate clearly the name, address, telephone/mobile number, E-mail ID of the OEM to enable the Bid to be returned unopened in case it is declared "Late".
- E. All the pages of the proposal must be sequentially numbered and must contain the list of contents with page numbers. Any deficiency in the documentation may result in the rejection of the Bid.
- F. The original proposal/bid shall be prepared in indelible ink. It shall contain no interlineations or overwriting, except as necessary to correct errors made by the OEM itself. Any such corrections must be initialed by the person (or persons) who sign(s) the proposals.
- G. Union Bank of India shall not be responsible for proposals misplaced, lost or premature opening, if the outer envelope is not sealed and/or marked/ super scribed as stipulated. This circumstance may be a cause for rejection of proposal and no communication will be entertained in this regard.
- H. Any proposal received by Union Bank of India after the last date and time for submission of bids shall be returned unopened. However, Union Bank of India reserves the right to extend the last date of submission of bids, in which case, all rights and obligations of Union Bank of India and the OEMs will thereafter be subject to the deadline as extended.
- I. The bids submitted by telex/telegram/ fax/e-mail/through internet link etc. shall not be considered. Union Bank of India shall not be responsible for any postal delay or non-receipt/ non- delivery of the documents.
- J. Any bid document not conforming to any one of the above terms will be rejected.
- K. In the first stage, duly stamped Integrity Pact (IP) signed by authorized signatory submitted by OEM will be reviewed and if these are as per prescribed format/ RFP document then only Technical Bid will be evaluated. OEMs satisfying the technical requirements as determined by the Bank and accepting the terms and conditions of this document only shall be shortlisted for commercial evaluation.

11.2 TENDER FEE

- A. OEM is required to pay tender fee of Rs. 3000/- in the form of Demand Draft in favor of Union Bank of India, payable at Mumbai from any of the nationalized/ scheduled commercial bank. (Non- Refundable).
- B. RFP document can be downloaded from Bank's website www.unionbankofindia.bank.in or from/ Government tender portal www.eprocure.gov.in.
- C. All costs and expenses [whether in terms of time or material or money] incurred by the Recipient/OEM in any way associated with the development, preparation, and submission of responses, including but not limited to attendance at meetings, discussions, demonstrations, etc. and providing any additional information required by the Bank, will be borne entirely and exclusively by the OEM.

11.3 PERFORMANCE GUARANTEE

- A. Performance Bank Guarantee amounting to ₹45.00 lakhs has to be submitted by the OEM on getting empanelment offer letter.
- B. The successful OEM shall provide a Performance Bank Guarantee within 10 days from the date of receipt of the offer, for the entire period of the contract i.e. 3 years and 60 days with a claim period and such other extended period as the Bank may decide for due performance of the project obligations. The PBG should be of scheduled commercial Bank, other than Union Bank of India.
- C. If the Performance bank guarantee is not submitted within the stipulated time, the Bank reserves the right to cancel the empanelment offer.

11.4 PERIOD OF VALIDITY OF BIDS:

Bids should remain valid for the period of at least 180 days from the last date for submission of bid prescribed by the Bank. In case the last date of submission of bids is extended, the OEM shall ensure that validity of bid is reckoned from modified date for submission. Further extension of the validity of the bid will be decided by the bank in case of need.

11.5 AMENDMENT OF BIDDING DOCUMENTS

Prior to the last date for bid-submission, Bank may, for any reason, whether at its own initiative or in response to clarification(s) sought from the prospective OEMs, modify the RFP contents/ covenants by amendment. Clarification /amendment, if any, will be notified on Bank's website. No individual communication would be made in this respect. In order to provide, OEMs, reasonable time to take the amendment into account for preparing their bid, the Bank may, at its discretion, extend the last date of submission of bids.

11.6 AUTHORIZATION TO BID

The proposal/ bid being submitted would be binding on the OEM. As such, it is necessary that authorized personnel of the firm or organization sign the bid documents. The designated personnel should be authorized by a senior official of the organization having authority.

- D. All pages of the bid shall be initialed by the person or persons signing the bid.
- E. Bid form shall be signed in full & official seal affixed on all the pages.
- F. Any inter-lineation, erasure or overwriting shall be valid only if they are initialed by the person or persons signing the Bid.
- G. All such initials shall be supported by a rubber stamp impression of the OEM's firm.
- H. The proposal must be accompanied with an undertaking letter duly signed by the designated personnel providing a bid commitment. The letter should also indicate the complete name and designation of the designated personnel.

11.7 SINGLE BID SYSTEM

- A. The Technical Bid should be complete in all respects and contain all information asked for in this document. It should not contain any financial information.
- B. The technical bid shall be submitted as hard copy on the Union Bank of India address in a sealed envelope.
- C. There shall be 2 sealed envelopes in the sealed main cover with the heading "Response to RFP for empanelment of OEMs for procurement of physical security products on

pan India basis”.

- D. Technical Bid Envelope 1: Sealed envelope to be marked as “Tender Fee”. Please affix the stamp of your company on the overleaf of both the demand drafts.
- E. Technical Bid Envelope 2: Sealed envelope to be marked as “Technical bid”
- F. The technical bid should be properly bound only. Loose documents will not be accepted. The name of work and tender should be clearly mentioned on the sealed envelope.
- G. The tenders which are not accompanied by tender fees will be rejected.
- H. The following documents are to be submitted in original-
 - Annexure A - Letter of Acceptance
 - Annexure B - Proposal for Empanelment of OEM Suppliers
 - Annexure C - Compliance to RFP Terms & Conditions
 - Annexure D - Format for Financial Summary
 - Annexure E - List of Projects (Completed and On-going)
 - Annexure F - Anti-Collusion Certificate
 - Annexure G- Bid Security Declaration
 - Annexure H- Declaration for Compliance
 - Annexure I - Confidentiality / Non-Disclosure Agreement
 - Annexure J - Empanelment Certificate
 - Annexure K: Format for Performance Bank Guarantee
 - Annexure L - Pre-Contract Integrity Pact (To be stamped as per agreement)
 - Annexure M - Bid Query Format
 - Annexure N - Certificate of Waiver for MSE Firms
 - Annexure O - Indemnity bond format
 - Annexure P - Undertaking for Testing

11.8 OPENING OF THE RFP/ TENDER

- A. Tender opening shall happen as per the details provided in “Important Dates & Details” in presence of officer authorized by Union Bank of India, in the presence of such of those OEMs or their representatives who may be present at the time of opening.
- B. The representatives of the OEMs are advised to carry the identity card or a letter of authority from the tendering firms to identify their bonafide for attending the opening of the proposal.
- C. Initial bid scrutiny will be held and incomplete details as given below will be treated as nonresponsive. If proposals:
 - Are not submitted in as specified in the RFP document
 - Received without the Letter of Authorization (Power of Attorney)
 - Are found with suppression of details
 - Submitted with incomplete information, subjective, conditional offers and partial offers
 - Submitted without the documents requested in the checklist
 - Have non-compliance of any of the clauses stipulated in the RFP

- With lesser validity period
- D. All responsive & eligible bids will be considered for further processing. Union Bank of India will prepare a list of responsive OEMs who comply with all the terms & conditions of the RFP.
 - E. Consortiums are not allowed for this engagement. The bidding entity has to be a single entity duly registered under the applicable laws of the country.

11.9 TECHNICAL BID EVALUATION

A. Checking of eligibility for Technical Evaluation

- i) Union Bank of India shall open the outer envelope marked as “Response to RFP empanelment of OEM suppliers for supply & installation of Physical Security Product’s in branches on pan India basis for Union bank of India”. The Bank will scrutinize the proposal and will determine whether the technical specifications along with documents have been furnished as per the Bid document.
- ii) If the contents of the Technical Bid envelope 1 marked as “Tender fee” are as per requirements, Union Bank of India shall open Technical Bid envelope 2 marked “Technical Bid”. Each of the eligibility criteria mentioned in this RFP is mandatory. In case the OEM does not meet any one of the conditions, the OEM will be disqualified.
- iii) Union Bank of India will constitute a proposal evaluation committee comprising of the Bank’s officials to evaluate the responses of the OEMs. The Committee will look into various parameters and thereafter pre-qualify eligible agencies who are fulfilling eligibility criteria mentioned in the tender.

B. Site visit to the manufacturing facility

The Bank’s representatives will visit the pre-qualify eligible OEM’s factory sites/offices and contact his past clients for verifications of information given by the applicants. The applicant will require to give them assistance for such verification. Bank will share the details (Name of Bank’s officials, date, time etc.) to respective OEM before visit. Site visit will be done by Technical evaluation committee members on the basis of eligibility criteria mentioned in the RFP.

- C. Based on eligibility criteria and after visiting to the manufacturing facility of OEM, the panel of prequalified OEM, so selected, will be valid for three years. The decision of the proposal evaluation committee in the evaluation of responses to the RFP shall be final. No correspondence will be entertained outside the process of evaluation with the committee. The proposal evaluation committee reserves the right to reject any or all proposals based on any deviations. Each of the responses shall be evaluated as per eligibility criteria and requirements specified in this RFP.

11.10 RFP CLARIFICATIONS

- A. The OEM is requested to collate and submit queries together to seek clarifications / responses from Bank. The OEM should ensure that all the queries and clarifications are communicated in email on or before the date given in the schedule of events of this RFP document. OEMs are requested to visit Bank’s website for clarifications and other communications.
- B. The OEMs will have to ensure that their queries for Pre-Bid meeting should reach to Union Bank of India procurement@unionbankofindia.bank.in by email 1 day before Prebid Meeting date. No oral or individual consultation shall be entertained. Any requests for clarifications after the indicated date and time will not be entertained by Union Bank of India.
- C. Any modification of the RFP, which may become necessary as a result of the queries, shall be made available by the Bank exclusively through the issue of an Addendum/ Corrigendum on

Queries and the clarifications shall be uploaded on the website www.unionbankofindia.bank.in as corrigendum to the RFP as well as on www.eprocure.gov.in

- D. Union Bank of India makes no representation or warranty as to the completeness or accuracy of any response made in good faith, nor does Union Bank of India undertake to answer all the queries that have been posed by the OEMs.
- E. The clarification of the Bank in response to the queries raised by the Applicants, and any other clarification/ amendments/ corrigendum furnished thereof will become part and parcel of the RFP and it will be binding on the Applicants.
- F. Non-receipt of reply to the queries raised by any of the Applicants shall not be accepted as a valid reason for non-submission of application. In addition, non-reply to any query may not be deemed the version of the Applicant as reflected in the query has been accepted by the Bank.
- G. The queries should necessarily be submitted in the Annexure M.

11.11 OTHER TERMS AND CONDITIONS OF RFP

- A. Responses to this RFP should not be construed as an obligation on the part of the Bank to award a purchase contract for any services or combination of services. Failure of the Bank to select an OEM shall not result in any claim whatsoever against the Bank. The Bank reserves the right to reject any or all bids in part or in full, without assigning any reason whatsoever.
- B. The OEM shall represent and acknowledge to the Bank that it possesses necessary experience, expertise and ability to undertake and fulfill its obligations, involved in the performance of the provisions of this RFP. If any services, functions or responsibilities not specifically described in this RFP are an inherent, necessary or customary part of the deliverables or services and are required for proper performance or provision of the deliverables or services in accordance with this RFP, they shall be deemed to be included within the scope of the deliverables or services, as if such services, functions or responsibilities were specifically required and described in this RFP and shall be provided by the OEM at no additional cost to the Bank. The OEM also acknowledges that the Bank relies on this statement of fact, therefore neither accepting responsibility for, nor relieving the OEM of responsibility for the performance of all provisions and terms and conditions.

11.12 MISCELLANEOUS RFP REQUIREMENT

This tender document may undergo change by either additions or deletions or modifications before issuing empanelment offer by the Bank. The Bank also reserves the right to change any terms and conditions including eligibility criteria of the tender document and its subsequent addendums as it deems necessary at its sole discretion.

- A. No Commitment to Accept any Tender - The Bank shall be under no obligation to accept the offer received in response to this Tender notice and shall be entitled to reject any or all offers including those received late or incomplete offers without assigning any reason whatsoever. The Bank reserves the right to make any changes in the terms and conditions of purchase. The Bank will not be obliged to meet and have discussions with any OEM, and / or to listen to any representations unless there is change in the terms and conditions of purchase. The Bank further reserves the right to reject any or all offers based on its own evaluation of the offers received, or on the basis of stability, capabilities, track records, reputation among users and other similar credentials of a OEM. When the Bank makes any such rejection, the Bank will not be bound to give any reason and/or justification in this regard to OEM.
- B. Erasures or Alterations - The offers containing erasures or alterations will not be considered. There should be no hand-written material, corrections or alterations in the offer. Technical details must be completely filled up. Correct technical information of the product being offered must be filled in. Filling up of the information using terms such as "OK", "accepted", "noted", "as given in brochure manual" is not acceptable. The Bank may treat the offers not

adhering to these guidelines as unacceptable.

12. TAXES AND DUTIES

- A. The OEM shall solely be responsible for all payments (including any statutory payments) to its employees and shall ensure that at no time shall its employees, personnel or agents hold themselves out as employees or agents of the Bank, nor seek to be treated as employees of the Bank for any purpose, including claims of entitlement to fringe benefits provided by the Bank, or for any kind of income or benefits.
- B. The OEM alone shall file all applicable tax returns for all of its personnel assigned hereunder in a manner consistent with its status as an independent contractor of services; and the OEM will make all required payments and deposits of taxes in a timely manner.
- C. Payment of all taxes i.e. GST (CGST/SGST/IGST) will be made at actual, on production of suitable evidence of payment by the OEM.
- D. The OEM shall be liable to pay all applicable corporate taxes and income tax that shall be levied according to the laws and regulations applicable from time to time in India.
- E. GST/Tax remittance mismatch amount between Bank and Vendor will be hold by Bank future bills till resolution.

13. REJECTION OF BID

The Bid is liable to be rejected if:

- A. The document does not bear signature of authorized person in each page and duly stamped.
- B. It is received through Fax/E-mail.
- C. Incomplete Bids, including non-submission or non-furnishing of requisite documents / Conditional Bids / Bids not conforming to the terms and conditions stipulated in this Request for proposal (RFP) are liable for rejection by the Bank.
- D. It is evasive or contains incorrect information.
- E. Any form of canvassing / lobbying /influence/ query regarding short listing, status etc. will be a disqualification.
- F. OEM should comply with all the points mentioned in the work of Scope of RFP, technical specifications and all other clauses of RFP. Non-compliance of any point will lead to rejection of the bid.
- G. Non-submission of Integrity Pact (IP).
- H. Non-submission of tender fee.
- I. Bid submitted through courier services will not be accepted.
- J. All the pages of the proposal must be sequentially numbered and must contain the list of contents with page numbers. Any deficiency in the documentation may result in the rejection of the Bid.
- K. Union Bank of India shall not be responsible for proposals misplaced, lost or premature opening, if the outer envelope is not sealed and/or marked/ super scribed as stipulated. This circumstance may be a cause for rejection of proposal and no communication will be entertained in this regard.
- L. From the time of submission of bids to the time of entering into the agreement with the selected OEM, if OEM wishes to contact Union Bank of India on any matter related to its proposal, it should do so only in writing. Any effort by the OEM to influence Union Bank of India in the proposal evaluation or agreement award decisions may result in rejection of the proposal

14. MODIFICATION AND WITHDRAWALS OF BID

- A. No bid can be modified or withdrawn by the OEM after the closing date and time for submission of bids.
- B. No bid shall be withdrawn in the intervening period between deadline for submission of bids and expiration of period of bid validity specified by OEM in the submitted bid. In the event of withdrawal of the bid by OEMs, the OEM is liable to be suspended from participation in any future tenders of the Bank for 2 years.
- C. Successful OEM will not be allowed to withdraw the bid.

15. RFP RESPONSE

- A. All submissions will become the property of Bank. Recipients shall be deemed to license, and grant all rights to, Bank to reproduce the whole or any portion of their submission for the purpose of evaluation, to disclose the contents of the submission to other Recipients who have registered a submission and to disclose and/or use the contents of the submission as the basis for any resulting RFP process, notwithstanding any copyright or other intellectual property right that may subsist in the submission of banking documents.
- B. Bid properly documented should be submitted by on or before stipulated date & time mentioned in the RFP.

16. PAYMENT TERMS

- A. Payment shall be released by respective Regional office/ Zonal Office/ CO vertical on submission of necessary proof and documents like original Invoices or as per GeM terms.
- B. TDS on payments will be deducted as applicable.
- C. All the payments will be made to vendor electronically in Indian Rupees only.
- D. Bank will pay invoices within 30 days from the date of receipt of physical invoice by the Bank, except for those portions of any invoice that the Bank disputes in good faith and in writing. No penalty /Interest will be paid for the delayed payment.
- E. Vendor has to show the bifurcation/details of GST (CGST/SGST/IGST) in every invoice.

17. LIQUIDATED DAMAGES (LD) FOR THE DELAY

- A. In case of deficiency or failure in due delivery of services/ products by the OEM Vendor it shall be liable to pay penalties/ liquidated damages @ 0.5% of the contract price per week up, to a max of 5% of contract value and/or cancellation of Purchase Order/ Contract.
- B. If the OEM Vendor does not perform satisfactorily or delays execution of the contract, the Bank reserves the right to get the same contract executed by another empaneled OEM Vendor of its choice by giving 7 (Seven) day's notice for the same. In this event, the original OEM Vendor is bound to make good the additional/ any expenditure, which the Bank may have to incur to carry out, for the execution of the same order/contract. Such additional expenditure shall be incurred by the bank within reasonable limits & at comparable price prevailing in the market. This clause is also applicable, if for any reason, the contract is cancelled.
- C. In addition to the cancellation of purchase order, the Bank reserves its right to invoke the Bank Guarantee or foreclose the Security Deposit given by the OEM Vendor for appropriation towards damages. Any penalties/ liquidated damages imposed on the OEM Vendor for non-performance may also be deducted from the payment to be made to the OEM Vendor or as deemed necessary.

18. AUTHORIZED SIGNATORY

The selected OEM shall indicate the authorized signatories who can discuss and correspond

with the Bank, with regard to the obligations under the contract. The selected OEM shall submit at the time of signing the contract a certified copy of the resolution of their board, authenticated by the company secretary, authorizing an official or officials of the OEM to discuss, sign agreements/contracts with the Bank, raise invoice and accept payments and also to correspond. The OEM shall provide proof of signature identification for the above purposes as required by the Bank.

19. CONFIDENTIALITY

The OEM must undertake that they shall hold in trust any Information received by them, under the Contract/Agreement, and the strictest of confidence shall be maintained in respect of such Information. The OEM has also to agree:

- A. To maintain and use the Information only for the purposes of the Empanelment and only as permitted by the Bank.
- B. To only make copies as specifically authorized by the prior written consent of the Bank and with the same confidential or proprietary notices as may be printed or displayed on the original.
- C. To restrict access and disclosure of Information to such of their employees, agents, strictly on a “need to know” basis, to maintain confidentiality of the Information disclosed to them in accordance with this Clause and
- D. To treat all Information as Confidential Information.
- E. The Selected OEM shall be required to sign a Non-Disclosure Agreement with Bank as per prescribed format within thirty days of issuing the empanelment letter.

20. INDEMNITY

1. The OEM vendor shall at its own expenses, indemnify, defend and hold harmless Union Bank of India and its officers, directors, employees, representatives, agents respective directors, and assigns from and against any losses and liability (including but not limited to liabilities, judgments, damages, losses, claims, costs and expenses, including attorney’s fees and expenses) that may be occurring due to, arising from or relating to:
 - a) a breach, non -performance or inadequate performance by the OEM vendor of any of the terms, conditions, covenants, representations, undertakings, obligations or warranties under this RFP; or
 - b) the acts, errors, representations, misrepresentations, willful misconduct or negligence of the vendor, its employees in performance of its obligations under this agreement; or
 - c) any deficiency in the services of the vendor; or
 - d) Violation of any applicable laws by the OEM vendor, its agents, employee’s representatives etc.; or damage caused to bank’s property/premises during transportation and installation which is also liable to be recovered from payment of bills.
2. In the event of the OEM vendor not fulfilling its obligations under this clause within the period specified in the notice issued by Union Bank of India, Bank has right to recover the amounts due to it under this provision from any amount payable to the OEM vendor under this project.

3. The indemnities under this clause are in addition to and without prejudice to the indemnities given elsewhere in this agreement.

21. NON-TRANSFERABLE OFFER

This Request for Proposal (RFP) is not transferable. Only the OEM who has submitted the bid will be eligible for further participation.

22. RESPONSIBILITY FOR COMPLETENESS

- A. Any supplies and services, which might not have been specifically mentioned in this tender but, are necessary for the installation, configuration, testing, commissioning, performance or completeness of the order, shall be provided/made available as per the time schedule for smooth and efficient operation and maintenance of the system under Indian conditions.
- B. The OEM shall be responsible for any discrepancies, errors and omissions in the technical details submitted by him/them, irrespective of whether these have been approved, reviewed or otherwise, accepted by the Bank or not. The OEM shall take all corrective measures arising out of discrepancies, errors and omissions in drawing and other information as mentioned above within the time schedule and without extra cost to the Bank.

23. MINIMUM WAGES

- A. The OEM hereby agrees and undertakes that during the subsistence of this agreement it will not employ any personnel/individual below the Minimum Wages fixed by appropriate Government on this behalf from time to time, as per the provisions of Minimum Wages Act. In this effect, OEM has to submit undertaking on their company letterhead signed by authorized signatory.
- B. The successful OEM will ensure strict compliance of all labour laws, insurance, minimum wages to the staff employed /deployed /engaged for the work assigned and the Bank will not be liable for any such persons/personnel of successful OEM and shall not be liable for any levies penalties etc. that may be imposed by the Authorities concerned for their action/inaction. There shall be no employer employee relationship whatsoever between the bank and the successful OEM /their employees and the OEM or his employees, staff, agents will not be entitled to any employment with Bank. In the event of any demand/fines/penalty made by any of the authorities on bank in respect of the conduct/actions taken by the OEM/their employees/ labourers, the Bank will be entitled to recover the said amounts from the bills/ amount payable or from the performance guarantee and also take appropriate action against said persons of OEM for their misconduct, if any.

24. FORCE MAJEURE

Force Majeure is herein defined as any cause, which is beyond the control of the selected OEM or the Bank as the case may be which they could not foresee or with a reasonable amount of diligence could not have foreseen and which substantially affect the performance of the Contract, such as:

- A. Natural phenomena, including but not limited to floods, droughts, earthquakes, epidemics,
- B. Acts of any Government, including but not limited to war, declared or undeclared, priorities, quarantines, embargoes,
- C. Terrorist attacks, public unrest in work area; Provided either party shall within ten (10) days from the occurrence of such a cause notify the other in writing of such causes. The OEM or the Bank shall not be liable for delay in performing his/her obligations resulting from any Force Majeure cause as referred to and/or defined above.

25. EXIT CLAUSE

The Bank reserves the right to cancel the Empanelment in the event of happening of one or more of the following conditions:

- a. Failure of the successful OEM to accept the empanelment offer within 30 days and furnish the requisite documents.
- b. Delay in delivery beyond the specified period
- c. Delay in completing implementation/customization beyond the specified period.
- d. Serious discrepancy in functionality to be provided or the performance levels which have an impact on the functioning of solution.

26. TERMINATION OF CONTRACT

If the Termination is on account of failure of the successful OEM to perform the obligations under this RFP contract, the Bank shall have the right to invoke the Performance Bank Guarantee(s) given by the selected OEM. The Bank will be entitled to terminate this empanelment for the period of three years, without any cost to the Bank and recover expenditure incurred by Bank, on the happening of any one or more of the following:

- The selected OEM commits a breach of any of the terms and conditions of the bid.
- The Successful OEM goes into insolvency/liquidation voluntarily or otherwise.
- An attachment is levied or continues to be levied for a period of 7 days upon effects of the empanelment offer.
- Non-satisfactory performance of the selected OEM during implementation and operation.
- An act of omission by the OEM, its employees, its agents, or employees of the consortium in the performance of the services provided by this RFP.
- Failure to integrate/implement the Project as per the requirements of the Bank as stated in this RFP.
- Material discrepancies in the Deliverables and Services noted in the implementation/maintenance of the Project. Bank reserves the right to procure the same or similar product from the alternate sources at the risk, cost and responsibility of the selected OEM.
- The OEM would be required to ensure that item requested by bank is delivered within given timeline. If delays of more than seven days but not beyond 15 days are observed in three deliveries, the OEM will be put on notice. Even after issue of notice, delay in supply of item indented is observed, the Bank will be free to de-panel the contractor without further notice. In case of delay, more than 15 days the Bank will be free to de-panel the contractor.
- Selected OEM is found to be indulging in frauds.
- The bank suffers a reputation loss on account of any activity of successful OEM leading to penalty levied by regulatory authority.
- In the event of subcontract or assignment contrary to the terms of agreement.

27. GOVERNING LAW & JURISDICTION

A. The agreement shall be governed by, construed and enforced in accordance with the laws of India. The parties agree that, except to the extent otherwise provided in the Act, the Rules and the Regulations, any action or suit involving this Agreement or the performance by either party of its obligations hereunder will be conducted exclusively in courts located within the city of Mumbai.

- B. The OEM shall continue work under the empanelment during the arbitration proceedings unless otherwise directed by the Bank or unless the matter is such that the work cannot possibly be continued until the decision of the arbitrator is obtained.

28. AUDIT

- A. The OEM shall at all times whenever required furnish all information, records, data stored in whatsoever form to internal, external, Bank appointed, and statutory/ RBI inspecting auditors and extend full cooperation in carrying out of such inspection. The OEM will also undertake to co- operate with the RBI/any regulatory agency of Central/State Govt. to carry out its supervisory functions and objectives and will furnish all records and other information as RBI may call for to carry our inspection and/ or other functions. The OEM is required to facilitate the same at no additional cost and shall provide uninterrupted access to the documents required by the auditors. Further the OEM has to ensure rectification of all the irregularities thus pointed out by the auditor within a given time frame.
- B. The OEM has to ensure compliance of Information Security according to policy of the Bank and mitigate the risk, if any, within the stipulated time without any additional cost to Bank.
- C. In line of above, the selected OEM shall ensure that all Regulatory, Statutory, Local Administration requirements are adhered to subsequently while undertaking deliverable and services over the period of contract without any additional cost to Bank.
- D. Any license violation on the part of the vendor shall not put Bank at risk. Bank shall reserve the right to audit the license usage of the vendor or shall ask the vendor to take undertaking of non-violation of license.
- E. OEM will permit Bank's auditor/ authorized auditors/Law enforcement agency personal/Regulatory authorities to access the premises for information and verification and cooperate to provide all information and documents without objection and additional cost.

29. PRE-BID MEETING

- A. For the purpose of clarifications of doubts of the OEMs on issues related to the RFP, Bank will hold a pre- bid meeting on the date & time as indicated in the RFP document. It may be noted that no query of any OEM shall be entertained/ received after the mentioned date. Queries raised by the prospective OEMs and the Bank's response will be available at Bank's web site and www.eprocure.gov.in. Only authorized representative of OEM (maximum two) will be allowed to attend the Pre-bid meeting. Interested OEMs are required to submit a letter from authorized signatory of the organization through the emails mentioned in this RFP along with details including name, organization, designation, Mobile number, etc.
- B. Non - attendance at the Pre-bid Meeting will not be a cause for disqualification of an OEM.
- C. Any modification of the RFP, which may become necessary as a result of the Pre- bid Meeting, shall be made public by the Bank exclusively through the issue of an Addendum/Corrigendum on Bank's website www.unionbankofindia.bank.in as corrigendum to the RFP as well as on www.eprocure.gov.in.

30. CONFLICT OF INTEREST

- A. Bank requires that OEM provide professional, objective and impartial services and at all times hold Bank's interest paramount, strictly avoid conflicts with other Assignment(s)/ Job(s) or their own corporate interests and act without any expectations/ consideration for award of any future assignments from Bank.
- B. OEM have an obligation to disclose any situation of actual or potential conflict in assignment/job, activities and relationships that impacts their capacity to serve the best interest of Bank, or that may reasonably be perceived as having this effect. If the OEM fails to disclose said situations and if Bank comes to know about any such situation at any time, it may lead to the disqualification of the OEM during bidding process or the termination of its Contract during execution of assignment.

C. Employees of Union Bank of India shall not work as, for or be a part of the firm of OEM. Similarly, employees of the agency shall not have any right of employment in the Bank.

31. RFP OWNERSHIP

The RFP and all supporting documentation are the sole property of Union Bank of India and should not be redistributed without prior written consent of Union Bank of India. Violation of this would be a breach of trust and may, inter-alia causes the OEMs to be irrevocably disqualified. The aforementioned material must be returned to Union Bank of India when submitting the proposal, or upon request; however, OEMs can retain one copy for reference.

32. TENDER/RFP CANCELLATION

The Bank reserves the right to cancel the Tender/RFP at any time without assigning any reasons whatsoever.

33. PUBLICITY

Any publicity by the OEM in which the name of the Bank is to be used, will be done only with the explicit written permission of the Bank.

34. ARBITRATION

A. All disputes, differences, claims and questions whatsoever which shall arise either during the subsistence of this RFP or afterwards between the parties hereto and/ or their respective representatives touching these presents or any clause or thing herein contained or otherwise in any way relating to or arising from these presents or the interpretation of any provision herein contained shall be in the first place settled by mutual discussions between the parties at highest level. If the disputes, differences, claims or questions is not so resolved within 30 days from the day the parties first initiate discussion, then the same shall be referred to the arbitral tribunal which shall be composed of three arbitrators, one arbitrator to be appointed by each Party and third arbitrator appointed by the mutual consent of the arbitrators so appointed before commencing the arbitration proceedings. The third arbitrators to be appointed shall be independent. The arbitration shall be held in accordance with the Arbitration and Conciliation Act, 1996 or any statutory modification or re-enactment thereof for the time being in force and shall be held in Mumbai and conducted in English language. The award of the arbitral tribunal shall be final and conclusive and binding upon the Parties.

B. The Courts in Mumbai shall have exclusive jurisdiction over such arbitration proceedings. The rights and obligations of the Parties under, or pursuant to, this Clause, including the arbitration agreement in this Clause, shall be governed by and subject to Indian law.

35. DISPUTE RESOLUTION & JURISDICTION

Notwithstanding anything contained herein above, in case of any dispute, claim and legal action arising out of this RFP, the parties shall be subject to the jurisdiction of courts at Mumbai, Maharashtra State, India only. Law of India will be applicable for dispute resolution.

36. INSTRUCTIONS, TERMS & CONDITIONS

A. Union Bank of India reserves the right:

- i) to accept or reject any or all the proposals.
- ii) to cancel the RFP process at any time without assigning any reasons, therefore.
- iii) to re-issue the RFP, if cancelled.
- iv) to empanel or engage any OEM other than by this RFP.

- B. The successful OEM Bidders in the present RFP process shall be required following:
- i. To execute Service Level Agreement (SLA) or Empanelment Agreement, as the case may be, which would include all the terms and conditions of delivery of services as detailed herein and any other conditions as may be prescribed by the Bank.
 - ii. To submit Performance Bank Guarantee amounting to ₹10.00 lakhs as per Annexure (K).
 - iii. To execute Confidentiality / Non-Disclosure Agreement as per Annexure (I).
 - iv. To submit Indemnity bond as per Annexure (O).
- C. The OEM personnel shall not disclose any confidential/ vital information which are disclosed/ provided to them during the course of briefing or any discussion or acquired by the OEM to any third party without prior permission of the Bank and such information shall be kept confidential even after the termination/expiry of the agreement. The empaneled OEMs will have to sign the non-disclosure agreement with the bank.
- D. Execution of the aforementioned documents by the authorized signatory of the successful/ selected OEM Bidder and submission of performance security shall be complied within 15 (fifteen) days from the date of acceptance of the Letter of Appointment, at their costs and expenditure.
- E. The Bank shall have right to de-panel an OEM or entire panel by way of issuing one-month notice during the validity period of the empanelment without assigning any reason. If an OEM does not respond to the requirements of the bank/performance is not upto the satisfaction of the Bank, the OEM would be de-paneled without assigning any reason therefor.
- F. The inclusion of OEMs in the Bank's panel does not guarantee any minimum business. It is further clarified that the empanelment of any OEM does not tantamount to an assurance by the Bank for the purpose of awarding the work. Further, empanelment of any OEM shall not prejudice the Bank's right to avail the services from any other OEM. In case any OEM closes any of its offices, it should immediately inform the Bank about the fact in writing.
- G. The OEMs shall seek the prior written approval of the bank before carrying out any market research, advertising research, public relations, consultancy services, supervisory services, printing etc. in respect of any assignment for the Bank.
- H. The bank shall make every effort to issue instructions and approval in writing to the OEMs. However, if the same is conveyed orally, the OEMs will get it confirmed immediately from the bank at the earliest in writing to avoid disputes.
- I. The bank reserves the right to withdraw the RFP or delete/amend/change/modify any clause(s) mentioned herein at any time, without assigning any reason and shall not be held liable for any losses or damages caused by such withdrawal/ amendment/modification. The withdrawal of RFP would be by serving a suitable letter by the bank to all the OEMs who have submitted their proposals, either on their addresses provided on the proposal or via email or by way of notice on the bank's website.
- J. The OEM shall indemnify Union Bank of India against any action or proceedings brought against Union Bank of India by reason of omission/ commission or negligence on its part or on the part of its employees/agents, in the performance of the said services. The agency shall be liable for any of its or its employees / agents' actions that are detrimental to interest of Union Bank of India and the quantum of damages for the same will be decided by the Bank which will be final and binding on the agency. The agency shall also indemnify Union Bank of India in respect of any third-party claim in respect of any Intellectual Property Rights (IPR) violations alleged or raised on account of the services provided by the agency to the Bank.
- K. Any dispute or differences whatsoever arising during the contract period between the empaneled agency and Union Bank of India shall be referred for arbitration to be considered

in accordance with the Arbitration & Conciliation Act, 1996 and the venue of arbitration shall be in Mumbai and language of Arbitration shall be English. The above stated terms and conditions are to be treated by the empaneled OEM as final. There will be no scope for further discussions or negotiations.

37. SUBMISSION OF BIDS

The OEM vendors have to submit responses to the RFP physically. All response documents as per requirement of RFP must be submitted along with the pre-qualification cum technical bid. The bids will be opened at the following address: -

To,

Union Bank of India,

Procurement Department
1st Floor, 239, Union Bank Bhavan,
Vidhan Bhavan Marg,
Nariman Point, Mumbai - 400 021

Bank may, at its discretion, extend this deadline for submission of bids by releasing corrigendum to this tender document.

38.

ANNEXURE A: Letter of Acceptance

(Letter to the bank on the OEM's letterhead)

To,

Date:

General Manager,
Union Bank of India,
Procurement Department,
Union Bank Bhavan,
239, 1st floor Vidhan Bhavan Marg,
Nariman Point, Mumbai 400021.

SUBJECT: RFP for empanelment of OEMs for procurement of physical security products in branches on pan India basis

With reference to the above subject, having examined and understood the instructions, terms and conditions forming part of it, we hereby enclose our offer for the desired empanelment process as detailed in your above referred RFP.

We further confirm that the offer is in conformity with the terms and conditions as mentioned in the bid and all required information as mentioned is enclosed.

We also confirm that the offer shall remain valid for 180 days from the date of the offer.

We understand that the Bank is not bound to accept the offer either in part or in full and that the Bank has right to reject the bid in full or in part without assigning any reasons whatsoever.

We understand that

- a. If our bid is accepted, we are to be responsible for the due performance of the empanelment.
- b. We enclose tender fee of Rs. 3,000.00 (Rupees three thousand Only) favoring Union Bank of India and payable at Mumbai, details of the same is as under:

No.:

Date:

Name of Issuing Bank:

Or

MSE/Udyog Aadhaar Certificate No.

We hereby declare that all the information & Statements made in this bid are true and accept that any misinterpretation contained in it may lead to our disqualification. We agree to all terms & conditions of the bid.

Dated at _____ this _____ day of _____ 2026.

We hereby declare that all the information & Statements made in this bid are true and accept that any misinterpretation contained in it may lead to our disqualification. We agree to all terms & conditions of the bid.

Date:

Yours faithfully,

For _____

Signature _____

Name _____

Authorized Signatories
(Name & Designation, seal of the firm)

ANNEXURE B: PROPOSAL FOR EMPANELMENT OF OEMs for procurement of physical security products in branches on pan India basis

BIO - DATA OF PROPOSER (OEM)

1. Name of the proposer (OEM) : _____
 Office Address : _____

 Telephone/ Contact No. : _____
 Office : _____
 Residence : _____
 E-Mail : _____
2. a) Whether proprietary/partnership/
 Pvt. Ltd. / Public Ltd. (certificate
 of registration / partnership deed
 to be enclosed as Annexure-I). : _____
- b) Name of the Proprietor, : _____
 Partners, Directors : _____
 I) _____
 II) _____
- c) Year of establishment : _____
3. Registration with Tax Authorities : _____
 i) Income-tax (PAN) No. : _____
 ii) GST No : _____
 iii) EPF Regn. No. : _____
 iv) ESI Regn. No. : _____

(Copies of certificates of registration with relevant authorities to be enclosed as Annexure-II-A, II-B, II-C, II-D & II-E)

4. Names of the Bankers with address & telephone numbers:
 39) II) _____
5. Furnish copies of audited balance-Sheet and Profit & Loss A/C. for the years i.e. 22-23, 23-24 & 24-25 as Annexure-III-A, III-B & III-C. : Enclosed / Not enclosed
6. Empanelment with minimum two Public Sector Banks, other than Union Bank of India (certificates of empanelment to be enclosed as Annexure-IV.

Sr. No.	Name of the Public Sector Bank	Year since empaneled
01)		
02)		

03)		
04)		

7. Give details if at present involved in litigation in similar type of contracts:

Sr. No.	Name of Project	Name of Employer	Nature of work	Work order dated	Date of completion of work	Value Rs.

8. Details of civil suit, if any, that arose during execution of contract in the past 10 years.

: _____

9. Name & relation, if any, with the staff member of Union Bank of India.

: _____

10. Details of work executed during the last 3 years:

Type of work	Work executed for (name of the Institution / Body)	Nature of work (in brief)	Location	Value Rs.	Duration of work with dt Commence completion		If work left incomplete or terminated (give reasons)

Note: Copies of work orders along with Xerox copies of relevant TDS certificate, satisfactory completion certificate obtained from the client shall be enclosed as Annexure V. Please note without the copies of certificates, your application is liable to be rejected.

11. Details of Empanelment with other Bank: _____
(Copies of work orders be enclosed as Annexure VI))

12. LIST OF NAME/S OF PROPRIETOR / PARTNERS & EMPLOYEES

Name	Qualifications	Experience	Particulars of work done	Employed in your firm since

13. Turnover in last five FY:

Sr. No.	Year	Turnover (Rs. In lakh)	Profit/Loss (Rs. In lakh)
1	2020-21		
2	2021-22		
3	2022-23		
4	2023-24		
5	2024-25		

Copies of income-tax returns/ assessment orders for each year to be enclosed as Annexure VII-A, B, C, D & E

Date : _____ Authorized Signatory : _____

Name : _____

Place : (Seal of firm) Designation : _____

ANNEXURE C: Compliance to RFP Terms & Conditions

S. No.	Clause Details	OEM's Compliance (Yes/No)
1.	INTRODUCTION	
2.	INTEGRITY PACT (IP)	
3.	OBJECTIVES OF THE RFP	
4.	DEFINITIONS	
5.	INVITATION OF TENDER BIDS	
6.	BASIC ELIGIBILITY CRITERIA	
7.	SPECIAL CONDITIONS OF CONTRACT	
8.	SCOPE OF RFP	
9.	PERIOD OF EMPANELMENT	
10.	COST OF BIDDING	
11.	LANGUAGE OF BID	
12.	INSTRUCTION FOR BID SUBMISSION	
13.	TAXES AND DUTIES	
14.	REJECTION OF BID	
15.	MODIFICATION AND WITHDRAWALS OF BID	
16.	RFP RESPONSE	
17.	PAYMENT TERMS	
18.	LIQUIDATED DAMAGES (LD)	
19.	AUTHORIZED SIGNATORY	
20.	CONFIDENTIALITY	
21.	INDEMNITY	
22.	NON-TRANSFERABLE OFFER	
23.	RESPONSIBILITY FOR COMPLETENESS	
24.	MINIMUM WAGES	
25.	FORCE MAJEURE	
26.	EXIT CLAUSE	
27.	TERMINATION OF CONTRACT	

28.	GOVERNING LAW & JURISDICTION	
29.	AUDIT	
30.	PREBID MEETING	
31.	CONFLICT OF INTEREST	
32.	RFP OWNERSHIP	
33.	TENDER/RFP CANCELLATION	
34.	PUBLICITY	
35.	ARBITRATION	
36.	DISPUTE RESOLUTION & JURISDICTION	
37.	INSTRUCTIONS, TERMS & CONDITIONS	
38.	SUBMISSION OF BIDS	
39.	ANNEXURE:	

(Authorized Signatory)

Place:

Date

Name: _____

Designation: _____

Business Address: _____

Email.id: _____

ANNEXURE D: Format for Financial Summary

(to be furnished by the OEM towards physical security products on their letter head)

All figures in Equivalent Currency (in Rs Lakhs)

Description	Turnover in Last Three Financial Years. - Audited			Average Turnover in the last three years.
	FY 2022-23	FY 2023-24	FY 2024-25	
Operating Revenue				
Other Revenue				
Total Turnover				
Operating Profit				

Financial Year: 1st April to 31st March

This is to certify that _____ (name of the Bidder) has Annual Turnover as shown above against the respective/s financial year/s.

Signature: _____

Name of the Statutory Auditor: _____

Membership No: _____

Designation: _____

Name of the Audit Firm: _____

FRN: _____

ANNEXURE E: List of Projects (Completed and On-going)

(to be furnished by the bidder on their letter head)

Sr. No	Client Name	Project Title & Brief Description	Location	Starting Date	Completion /Expected Completion Date
1					
2					
3					
4					
5					

Dated this _____ Day of _____, 2026

Name of the Bidder:

Signature of the Authorized Signatory:

Name of the Authorized Signatory:

**ANNEXURE F: Anti-Collusion Certificate
(to be furnished by the Bidder on their letter head)**

To,

The General Manager,
Union Bank of India,
Union Bank Bhavan,
1st Floor, Procurement Dept
239, Vidhan Bhavan Marg,
Nariman Point, Mumbai-400021.

Subject: Application for Tender for empanelment of OEMs for procurement of physical security products in branches on pan India basis

Dear Sir,

We hereby certify and confirm that in the preparation and submission of this Proposal, we have not acted in concert or in collusion with any other Bidder or any other person(s). And also, not done any act, deed or thing which is or could be regarded as anticompetitive, restrictive or monopolistic trade practice.

We further confirm that we have not offered nor will offer any illegal gratification in cash or kind to any person or agency in connection with this Proposal.

Dated this _____ Day of _____, 2026

Name of the Bidder:

Signature of the Authorized Signatory:

Name of the Authorized Signatory:

ANNEXURE - G: Bid Security Declaration

To,

The General Manager,
Union Bank of India,
Union Bank Bhavan,
1st Floor, Procurement Dept
239, Vidhan Bhavan Marg,
Nariman Point, Mumbai-400021.

Subject: Application for empanelment of OEMs for procurement of physical security products in branches on pan India basis

.

Dear Sir,

We _____(bidder name), hereby undertake that we are liable to be suspended from participation in any future Tenders/TENDER of the Bank for 2 years from the date of submission of Bid in case of any of the following:

1. If the bid submitted by us is withdrawn/modified during the period of bid validity.
2. If any statement or any form enclosed by us as part of this Bid turns out to be false / incorrect at any time during the period of prior to signing of Contract.

Date:

Yours faithfully,

For _____

Signature _____

Name _____

Authorized Signatories
(Name & Designation, seal of the firm)

ANNEXURE H - Declaration for Compliance

All Terms and Conditions including scope of work and technical specifications

We hereby undertake and agree to abide by all the terms and conditions, technical specifications stipulated by the Bank in this Tender including all addendum, corrigendum etc. (Any deviation may result in disqualification of bids).

Signature:

Name:

Date:

Seal of company:

ANNEXURE I - Confidentiality / Non-Disclosure Agreement

This CONFIDENTIALITY AGREEMENT (the “Agreement”) entered into on this ___ day of 2026, and shall be deemed to have become in full force and effect from (the “Effective Date”).

BY and between M/s. _____ a company incorporated under the provisions of the Companies Act, _____ in force in India, having its registered office at _____ (hereinafter referred to as “.....” or “Vendor” which expression shall, unless it be repugnant or contrary to the context or meaning thereof, mean and include its, successors and permitted assigns) of the ONE PART

AND

Union Bank of India, a corresponding new bank constituted under section 3 of Banking Companies (Acquisition & Transfer of Undertakings) Act 1970 having its Head office at Union Bank Bhavan, Vidhan Bhavan Marg, Nariman Point, Mumbai - 400021 (hereinafter referred to as “Union Bank” or “Bank” which expression shall, unless it be repugnant to the context or meaning thereof, mean and include its successors and permitted assigns), of the OTHER PART:

_____ and the Bank shall hereinafter jointly be referred to as “Parties” and individually as a “Party”.

In this Agreement, “Affiliate” means any entity which from time to time Controls, is Controlled by or is under common Control with the relevant party or entity, where “Control” means having the ability (including, without limitation, by means of a majority of voting rights or the right to appoint or remove a majority of the board of directors) to control the management and policies of an entity.

WHEREAS: -

Vendor inter-alia is engaged in the business of providing.

Union Bank has agreed to disclose, transmit, receive, and/or exchange certain “confidential information” to cover the business transaction between parties for the provision of services related to “_____” (“the Purpose”) as more particularly described in various Purchase Order(s) as and when issued by Union Bank in favor of M/s. _____.

NOW THIS AGREEMENT WITNESS:

1. Interpretation

In this Agreement “Confidential Information” means all information belonging to a Party that is or has been disclosed to one Party (the “Receiving Party”) by the other Party (the “Disclosing Party”) in connection with the business transacted/ to be transacted between the Parties. Confidential information shall also include any copy, abstract, extract, sample, note or module thereof. The Receiving Party may use the Confidential Information solely for and in connection with the business transacted/ to be transacted between the Parties.

Notwithstanding the foregoing, “Confidential Information” shall not include any information which the Receiving Party can show: (a) is now or subsequently becomes or is in possession of the Receiving Party, legally and publicly available without breach of this Agreement by the Receiving Party, (b) was rightfully in the possession of the Receiving Party without any obligation of confidentiality prior to receiving it from the Disclosing Party, (c) was rightfully obtained by the Receiving Party from a source other than the Disclosing Party without any obligation of confidentiality, (d) was developed by or for the Receiving Party independently and without reference to any Confidential Information and such independent development can be shown by documentary evidence, or (e) is disclosed pursuant to an order of a court or governmental agency as so required by such order, provided that the Receiving Party shall,

unless prohibited by law or regulation, promptly notify the Disclosing Party of such order and afford the Disclosing Party the opportunity to seek appropriate protective order relating to such disclosure.

2. Confidentiality:

2.1. Except to the extent as agreed herein, the Receiving Party agrees to regard, preserve and keep as secret and confidential all Confidential Information of the Disclosing Party or its clients or any member of their group disclosed under this Agreement. In maintaining confidentiality hereunder, the Receiving Party agrees and accepts that it shall not, either on its own account or jointly with or for any other person, firm, company or any other entity, without obtaining the written consent of the disclosing party.

- I. disclose, transmit, reproduce or make available any such Confidential Information to any person firm, company or any other entity other than its directors, partners, advisers, agents or employees, who need to know the same for the purpose of evaluating, preparing, considering, negotiating, advising in relation to or in furtherance of the purpose aforesaid; or
- II. use the Confidential Information for any purpose other than evaluating, preparing, considering, negotiating, advising in relation to or in furtherance of the purpose for which it is disclosed; or
- III. disclose, announce or otherwise publicize the existence of its association with the Disclosing Party or the existence of the project with the Disclosing Party or any other arrangement (existing or possible) between the disclosing party, its clients or itself in connection with any project/assignment; or
- IV. use any such Confidential Information for its own benefit or the benefit of others or do anything prejudicial to the interests of the Disclosing Party or its clients or any member of their group or their projects.

2.2. The Receiving Party also agrees and accepts that it may endeavor:

- I. use at least the same degree of care in safeguarding such Confidential Information as it uses for its own Confidential information of like importance and such degree of care shall be at least that which is reasonably calculated to prevent such inadvertent disclosure;
- II. keep the Confidential Information and any copies thereof secure and in such a way so as to prevent unauthorized access by any third party;
- III. limit access to such Confidential Information to those of its (including its Affiliates“) directors, partners, advisers, agents or employees who are directly involved in the consideration/evaluation of the Confidential Information and bind each of its directors, partners, advisers, agents or employees so involved to protect the Confidential Information in the manner prescribed in this Agreement; and
- IV. upon discovery of any disclosure or suspected disclosure of Confidential Information, to take reasonable effort to as per the circumstances, to inform the Disclosing Party of such disclosure in writing and immediately return to the Disclosing Party all such Information, in whatsoever form, including any and all copies thereof.

3. Return or destruction:

The Receiving Party may, upon completion of the purpose mentioned aforesaid or at any time on receipt of a written demand from the disclosing party: i) immediately return all written Confidential Information and all copies thereof provided to, or produced by, it or its advisers, as the case may be, which is in such party’s possession or under its custody and control; ii) to the extent practicable, but without prejudice to the obligations of confidentiality herein,

immediately destroy all analyses, compilations, notes, studies, memoranda or other documents prepared by it or its advisers to the extent that the same contain, reflect or derive from Confidential Information relating to the other party; iii) so far as it is practicable to do so (but, in any event, without prejudice to the obligations of confidentiality contained in this Agreement), immediately expunge any Confidential Information relating to the Disclosing Party or its clients or any member of their group or their projects from any computer, word processor or other device in its possession or under its custody and control.

4. Permitted disclosure:

The provisions of paragraph 2 shall not restrict any disclosure required by law or by any court of competent jurisdiction, the rules and regulations of any recognized stock exchange or any enquiry or investigation by any governmental, official or regulatory body which is lawfully entitled to require any such disclosure provided that, so far as it is lawful and practical to do so prior to such disclosure, the Receiving Party shall promptly notify the other party of such requirement with a view to providing the opportunity for the Provider to contest such disclosure or otherwise to agree the timing and content of such disclosure.

5. Ownership of Information:

Except to the extent as agreed herein, the Confidential Information and copies thereof, in whatsoever form shall at all times remain the property of the Disclosing Party or its clients and its disclosure shall not confer on the Receiving Party any rights (including any intellectual property rights) over the Confidential Information whatsoever beyond those contained in this Agreement.

6. No Representation:

Neither the disclosure, transmission receipt or exchange of Confidential Information nor anything else in this Agreement will constitute an offer by or on behalf of the Disclosing Party or be construed as soliciting any business or organization changes or any assurance of any business commitment or an inducement to incur / undertake any obligations not specified herein and neither party will be under any obligation to accept any offer or proposal which may be made by the other or on behalf of such other party.

7. Remedies and Relief:

The parties hereto acknowledge that remedies at law may be inadequate to protect the Disclosing Party or its clients against any actual breach of this Agreement by the Receiving Party, and, without prejudice to any other right and remedies otherwise available to the Disclosing Party or its clients, the Receiving Party agrees that Disclosing Party has a right to seek injunctive relief in its favor upon proof of actual damage and upon establishment of the fact that such actual damage has taken place due to reasons directly attributable upon the Receiving Party. Such injunctive relief shall be in addition to any other remedies available hereunder, whether at law or equity. Disclosing Party shall be entitled to recover its cost and fees, including Advocate's fees, incurred in obtaining any such relief. Further, in the event of litigation relating to this Agreement, the prevailing party shall be entitled to recover its cost and expenses including Advocate's fees.

8. No Assignment

This Agreement shall not be assigned by the vendor, by operation of law or otherwise, without the prior written consent of Bank. This Agreement shall inure to the benefit of and will be binding upon the parties' respective successors and permitted assigns.

9. Severability

In the event that any of the provisions contained in this Agreement is found to be invalid, illegal or unenforceable in any respect by a Court of competent jurisdiction, the validity, legality, or enforceability of the remaining provisions contained in this agreement will not be in any way affected or impaired by such a finding.

10. Delay or Waiver

No delay or failure of either Party in exercising any right hereunder and no partial or single exercise thereof shall be deemed of itself to constitute a waiver or an expectation of non-enforcement of such right or any other rights hereunder. No waiver of any provision of this Agreement shall be valid unless the same is in writing and signed by the party against whom such waiver is sought to be enforced. A waiver or consent given by either party on any one occasion is effective only in that instance and will not be construed as a bar to or waiver of any right on any other occasion.

11. Notices

Notices as required by this Agreement shall be sent to the Parties at the addresses mentioned first herein above or such other addresses as the Parties may designate from time to time and shall be sent by certified or registered mail with acknowledgement due on receipt.

12. Term

This Agreement shall commence from the Effective Date of this Agreement and shall be valid for 6 months beyond contract period. Confidentiality obligations under this Agreement shall continue to be binding and applicable without limit in point in time except and until such information enters the public domain, without breach of the agreement. Either Party may terminate this Agreement for breach, if the defaulting Party fails to rectify the breach within the one-month notice period issued by the non-defaulting Party. Upon expiration or termination as contemplated herein the Receiving Party shall immediately cease any and all disclosures or uses of Confidential Information; and at the request of Disclosing Party, the Receiving Party shall promptly return or destroy all written, graphic or other tangible forms of the Confidential Information and all copies, abstracts, extracts, samples, notes or modules thereof.

13. Governing Law

The provisions of this Agreement shall be governed by the laws of India and shall be subject to the exclusive jurisdiction of courts in Mumbai.

14. Indemnity

The Receiving Party agree to indemnify and hold harmless the Disclosures against all costs, liability, losses and claims incurred by the Disclosing Party as a result of a breach of this Agreement.

15. Modification

Modification to any of the provisions of this Agreement shall be void unless it is writing and duly executed by Parties.

16. Headings

The headings given herein above are for ease of reference only and shall not attach or have any effect/ meaning whatsoever contrary to what is stated in the agreement.

17. Set off

Without prejudice to other rights and remedies available to the bank, bank shall be entitled to set off or adjust any amounts due to the bank from vendor against any payments due and payable by bank for the services rendered.

18. Review of Contract and performance

Bank shall have the right of periodical /yearly review of the performance of the vendor with regard to upgradation of processors, memory and storage space and maintenance support under the contract which would be basis of continuation or termination of the same. Bank shall also have the right to review, either itself or through another agency as it may deem fit, the

financial and operating performance of the bidder in order to assess the ability of the bidder to continue to meet its outsourcing/contractual obligations.

19. Proprietary Rights:

The entire work product mentioned in this RFP shall be the sole and exclusive property of the Bank. The vendor hereby-irrevocably grants, assigns, transfers to the Bank all rights, title and interest of any kind, in and to the work product produced under RFP contract. All information processed, stored, or transmitted by vendor belongs to the Bank. The Bidder does not acquire implicit access rights to the information or rights to redistribute the information. The Bidder understands that civil, criminal, or administrative penalties may apply for failure to protect information appropriately. Any information considered sensitive by the bank must be protected by the vendor from unauthorized disclosure, modification or access. The bank's decision will be final.

The vendor will ensure strict compliance of all labour laws, insurance, minimum wages to the staff employed

/deployed /engaged for the work assigned and the Bank will not be liable for any such persons/personnel of vendor and shall not be liable for any levies / penalties etc. that may be imposed by the authorities concerned for their action/inaction. There shall be no employer employee relationship whatsoever between the bank and the vendor

/their employees and the bidder or his employees, staff, agents will not be entitled to any employment with Bank. In the event of any demand/fines/penalty made by any of the authorities on bank in respect of the conduct/actions taken by the bidder/their employees/labourers, the Bank will be entitled to recover the said amounts from the bills / amount payable or from the performance guarantee and also take appropriate action against said persons of bidder/bidder for their misconduct, if any.

20. Counterparts

This Agreement has been signed in duplicate, each of which shall be deemed to be an original. The exchange of a fully executed Agreement (in counterparts or otherwise) by fax shall be sufficient to bind the parties to the terms and conditions of this Agreement.

IN WITNESS WHEREOF THE PARTIES HERETO HAVE CAUSED THIS AGREEMENT TO BE EXECUTED BY THEIR AUTHORIZED REPRESENTATIVES ON THIS DAY OF 2026

Signed and delivered by
M/s _____

Signed by:

Name

Title

in the presence of

.....

Signed and delivered by

Union Bank of India

Signed by:

Name

Title

in the presence of

.....

ANNEXURE J: Empanelment Certificate

(On letterhead of the Company duly stamped and signed)

Date:

TO WHOM SO EVER IT MAY CONCERN

This is to certify that M/s..... is our empaneled OEM suppliers for supply & installation of Physical Security Product's for more than.....years. The performance of the agency is satisfactory during their tenure with us.

(AUTHORISED SIGNATORY)

NAME:

DESIGNATION:

ANNEXURE K: - Format for Performance Bank Guarantee (Covering Delivery obligations)

To,

Union Bank of India,
Procurement Department,
1st floor, 239, Central Office, Vidhan
Bhawan Marg, Nariman point,
Mumbai-400 021

Dear Sir,

In consideration of Union Bank of India, **Procurement Department, 1st Floor, Central Office, 239, Union bank Bhavan, Vidhan Bhavan Marg, Nariman Point, Mumbai - 400 021** placing an order for Request for Proposal (RFP) for empanelment of OEMs for procurement of physical security products in branches on pan India basis to M/s _____ having registered office at _____ (hereinafter called the vendor) as per the empanelment contract entered into by the vendor vide empanelment offer letter no _____ dated _____ (hereinafter called the said contract), we _____ (Name of the Guarantor Bank), a 'schedule bank', issuing this guarantee through its branch at _____ presently located at _____ (hereinafter called the bank), do hereby irrevocably and unconditionally guarantee the due performance of the vendor as to the) for Request for Proposal (RFP) for empanelment of OEMs for procurement of physical security products in branches on pan India basis as per the said contract entered into by the vendor with you.

We _____ (Name of the Guarantor Bank), further agree that this guarantee shall continue to be valid will you unless you certify that the vendor has fully performed all the terms and conditions of the said contract and accordingly discharge this guarantee, or until _____, whichever is earlier. Unless a claim or demand is made on us in writing under this guarantee on or before _____, we shall be discharged from all our obligations under this guarantee. If you extend the schedule dates of performance under the said contract, as per the terms of the said contract, the vendor shall get the validity period of this guarantee extended suitably and we agree to extend the guarantee accordingly at the request of the vendor and at our discretion, provided such request is served on the bank on or before _____.

Failure on part of the vendor in this respect shall be treated as a breach committed by the vendor and accordingly the amount under this guarantee shall at once become payable on the date of receipt of demand made by you for payment during the validity of this guarantee or extension of the validity period.

You will have fullest liberty without affecting this guarantee to postpone for any time or from time to time any of your rights or powers against the vendor and either to enforce or forebear to enforce any or all of the terms and conditions of the said contract. We shall not be released from our liability under this guarantee by the exercise of your liberty with reference to matters aforesaid or by reason of any time being given to the vendor or any other forbearance act or omission on your part or any indulgence by you to the vendor or by any variation or modification of the said contract or any other act, matter or thing whatsoever which under the law relating to sureties would but for the provisions hereof have the effect of so releasing us from our liability hereunder.

In order to give full effect to the guarantee herein contained you shall be entitled to act as if we are your principal debtors in respect of all your claims against the vendor hereby guaranteed by us as aforesaid and we hereby expressly waive all our rights of surety ship and other rights if any which are in any way inconsistent with the above or any other provision of this guarantee.

The words the vendor, the beneficiary of this guarantees i.e. Yourself, and ourselves i.e. _____ (Name of the Guarantor Bank), unless repugnant to the context or otherwise shall include their assigns, successors, agents, legal representatives. This guarantee shall not be affected by any change in the constitution of any of these parties and will ensure for and be available to and enforceable by any absorbing or amalgamating or reconstituted company or concern, in the event of your undergoing any such absorption, amalgamation or reconstitution.

This guarantee shall not be revocable during its currency except with your prior consent in writing. This guarantee is non-assignable and non-transferrable.

Notwithstanding anything contained herein above:

I) Our liability under this bank guarantee shall not exceed 3% of the TCO.

II) This bank guarantee shall be valid up to _____.

III) We are liable to pay the guaranteed amount or any part thereof under this bank guarantee only if you serve upon us a written claim or demand (and which should be received by us), on or before _____ 12:00 hours (Indian standard time) where after it ceases to be in effect in all respects whether or not the original bank guarantee is returned to us.

This guarantee deed must be returned to us upon expiration of the period of guarantee.

Signature

Name

(In Block letters)

Designation

(Staff Code No.)

Official address:

(Bank's Common Seal)

Attorney as per power of Attorney No.

Date:

WITNESS:

1.....(Signature with Name, Designation & Address)

2.....(Signature with Name, Designation & Address)

Note:

1. This guarantee should be furnished by a Nationalized Bank/ Scheduled Bank, other than Union Bank of India, as per the following format.
2. The stamp paper should be purchased either in the Name of the Bank executing the Guarantee or in the name of Union Bank of India.
3. This Bank Guarantee should be furnished within 15 days from the date of from the date
4. This Bank Guarantee should be directly sent to the Purchaser by the Issuing Bank under Registered Post Acknowledge Due.

ANNEXURE L: Pre-Contract Integrity Pact (To be Stamped as an Agreement)

INTEGRITY PACT

Between

Union Bank of India having its registered office at Union Bank Bhavan, 239, Vidhan Bhavan Marg, Nariman Point, Mumbai, India -400 021 hereinafter referred to as “The Principal,” and _____ hereinafter referred to as “The Bidder.”

Preamble

The principal intends to award contracts for, under laid down organizational procedures, The Principal values full compliance with all relevant laws of the land, rules, regulations, economical use of resources, and fairness/ transparency in its relations with its Bidder(s). To achieve these goals, the principal shall appoint Independent External Monitors (IEMs) who shall monitor the tender process and the execution of the contract for compliance with the abovementioned principles.

Section 1 - Commitments of the Principal

- 2) The principal commits itself to take all measures necessary to prevent corruption and to observe the following principles: -
 - a) No employee of the principal, personally or through family members, shall in connection with the tender for, or the execution of a contract, demand, take a promise for or accept, for self or third person, any material or immaterial benefit which the person is not legally entitled to.
 - b) The principal shall treat all Bidder(s) with equity and reason during the tender process. The principal shall, in particular, before and during the tender process, provide to all Bidder(s) the same information and shall not provide to any Bidder(s) confidential / additional information through which the Bidder(s) could obtain an advantage in the tender process or the contract execution.
 - c) The principal shall exclude from the process all known persons having conflict of interest.
- 3) If the Principal obtains information on the conduct of any of its employees which is a criminal offence under the IPC/PC Act, or if there be a substantive suspicion in this regard, the principal shall inform the Chief Vigilance Officer and in addition shall initiate disciplinary proceedings.

Section 2 - Commitments of the Bidder(s)

- 1) The Bidder(s)/ Contractor(s) commits themselves to take all measures necessary to prevent corruption. The Bidder(s) commits themselves to observe the following principles during participation in the tender process and the contract execution.
 - a) The Bidder(s) shall not, directly or through any other person or firm, offer, promise, or give to any of the Principal's employees involved in the tender process or the execution of the contract or to any third person any material or other benefit which they are not legally entitled to, in order to obtain in exchange any advantage of any kind whatsoever during the tender process or the execution of the contract.
 - b) The Bidder(s) shall not enter with other Bidders into any undisclosed agreement or understanding, whether formal or informal, in violation of the Competition Act, 2002 (as amended from time to time). This applies in particular to prices, specifications, certifications, subsidiary contracts, submission or non-submission of bids or any other actions to restrict competitiveness or to introduce cartelization in the tender process.
 - c) The Bidder(s) shall not commit any offence under the relevant IPC/PC Act; further,

the Bidder(s) shall not use improperly, for purposes of competition or personal gain, or pass on to others, any information or document provided by the Principal as part of the business relationship, regarding plans, technical proposals, and business details, including information contained or transmitted electronically.

- d) The Bidder(s) of foreign origin shall disclose the name and address of the Agents/representatives in India, if any. Similarly, the Bidder(s) of Indian Nationality shall furnish the name and address of the foreign principals, if any. Further details, as mentioned in the "Guidelines on Indian Agents of Foreign Suppliers," shall be disclosed by the Bidder(s)/Contractor(s). Further, as mentioned in the Guidelines, all the payments made to the Indian agent/representative must be in Indian Rupees only. Copy of the "Guidelines on Indian Agents of Foreign Suppliers" is placed on Annex hereto.
 - e) The Bidder(s) shall, when presenting their bid, disclose any and all payments made, is committed to, or intends to make to agents, brokers, or any other intermediaries in connection with the award of the contract.
 - f) Bidder(s) who have signed the Integrity Pact shall not approach the Courts while representing the matter to IEMs and shall wait for their decision.
- 2) The Bidder(s) shall not instigate third persons to commit offences outlined above or be an accessory to such offences.

Section 3 - Disqualification from the tender process and exclusion from future contracts

If the Bidder(s), before award or during execution, has committed a transgression through a violation of Section 2, above or in any other form such as to put their reliability or credibility in question, the Principal is entitled to disqualify the Bidder(s) from the tender process or take action as per laid down procedure to debar the Bidder(s) from participating in the future procurement processes of the Union of India.

Section 4 - Compensation for Damages

- 1) If the Principal has disqualified the Bidder(s) from the tender process before the award according to Section 3, the principal is entitled to demand and recover the damages equivalent to Bid Security.
- 2) If the Principal has terminated the contract according to Section 3, or if the principal is entitled to terminate the contract according to Section 3, the principal shall be entitled to demand and recover from the Contractor liquidated damages of the Contract value or the amount equivalent to Performance Bank Guarantee.

Section 5 - Previous transgression

1. The Bidder declares that no previous transgressions occurred in the last three years with any other Company in any country conforming to the anti-corruption approach or with any Public Sector Enterprise in India that could justify his exclusion from the tender process.
2. If the Bidder makes an incorrect statement on this subject, the principal shall act like para of Section 4 above.

Section 6 - Equal treatment of all Bidders

In the case of Sub-contracting, the Principal Contractor shall take responsibility for adopting the Integrity Pact by the Sub-contractor.

- a) The principal shall enter into agreements with identical conditions as this one with all Bidders.
- b) The principal shall disqualify from the tender process all bidders who do not sign this Pact or violate its provisions.

Section 7 - Criminal charges against violating Bidder(s)

If the Principal obtains knowledge of the conduct of a Bidder or of an employee or a representative or an allied firm of a Bidder which constitutes corruption, or if the principal has substantive suspicion in this regard, the principal shall inform the same to the Chief Vigilance Officer.

Section 8 - Independent External Monitor

- 1) The principal shall appoint competent and credible Independent External Monitor(s) for this Pact after approval by the Central Vigilance Commission. The task of the Monitor is to review, independently and objectively, whether and to what extent the parties comply with the obligations under this agreement.
- 2) The Monitor is not subject to instructions by the parties' representatives and performs their functions neutrally and independently. The Monitor would have access to all Contract documents whenever required. It shall be obligatory for them to treat the information and documents of the Bidders as confidential. They report to the Management of the Principal.
3. The Bidder(s) accepts that the Monitor has the right to access without restriction, all Project documentation of the principal, including that provided by the Contractor. Upon their request and demonstration of a valid interest, the Bidder shall also grant the Monitor unrestricted and unconditional access to their project documentation.
4. The Monitor is under contractual obligation to treat the information and documents of the Bidder(s) with confidentiality. The Monitor has also signed declarations on 'Non-Disclosure of Confidential Information' and 'Absence of Conflict of Interest.' In case of any conflict of interest arising later, the IEM shall inform the Management of the Principal and recuse themselves from that case.
5. The principal shall provide the Monitor with sufficient information about all meetings among the parties related to the Project, provided such meetings could impact the contractual relations between the Principal and the Bidder. The parties offer the Monitor the option to participate in such meetings.
6. As soon as the Monitor notices, or believes to notice, a violation of this agreement, they shall inform the Management of the Principal and request the Management to discontinue or take corrective action or other relevant action. The Monitor can, in this regard, submit non-binding recommendations. Beyond this, the Monitor has no right to demand from the parties that they act in a specific manner, refrain from action, or tolerate action.
7. The Monitor shall submit a written report to the Management of the Principal, within 8 to 10 weeks from the date of reference or intimation to him by the Principal and, should the occasion arise, submit proposals for correcting problematic situations.
8. If the Monitor has reported to the Management of the Principal a substantiated suspicion of an offence under the relevant IPC/ PC Act, and the Management of the Principal has not, within the reasonable time, taken visible action to proceed against such offence or reported it to the Chief Vigilance Officer, the Monitor may also transmit this information directly to the Central Vigilance Commissioner.
9. The word 'Monitor' would include both singular and plural.

Section 9 - Pact Duration

This Pact begins when both parties have legally signed it. It expires for the bidder 12 months after the last payment under the contract, and for all other Bidders, 6 months after the contract has been awarded. Any violation of the same would entail disqualifying the bidders and exclusion from future business dealings.

If any claim is made / lodged during this time, the same shall be binding and continue to be valid despite the lapse of this Pact as specified above, unless it is discharged / determined by the Management of the Principal.

Section 10 - Other provisions

- 1) This agreement is subject to Indian Law. The place of performance and jurisdiction is the place from where the Tender/ Contract is issued.

- 2) Changes, supplements, and termination notices must be submitted in writing. Side agreements have not been made.
- 3) If the bidder is a partnership or a consortium, this agreement must be signed by all partners or consortium members.
- 4) Should one or several provisions of this agreement turn out to be invalid, the remainder of this agreement remains valid. In this case, the parties shall strive to come to an agreement according to their original intentions.
- 5) Issues like Warranty / Guarantee, etc., shall be outside the purview of IEMs.
- 6) In the event of any contradiction between the Integrity Pact and its Annex, the Clause in the Integrity Pact shall prevail.

(For & On behalf of the Principal)

(For and on behalf of Bidder)

(Office Seal)

(Office Seal)

Place _____ Date _____

Witness 1: _____

Witness 1: _____

(Name & Address) _____

(Name & Address) _____

ANNEXURE M: Bid query format

OEMs have to provide their queries on eligibility criteria, scope of work, terms & conditions etc. in excel format as mentioned below. OEMs are requested to categorize their queries under appropriate headings. OEMs are requested to provide a reference of the page number, state the clarification point and the queries/suggestion/deviation that they propose as shown below (all the queries will be entertained in this Microsoft Excel format by e-mail):

Queries will not be accepted in any other format other than Microsoft Excel.

Sl. No.	Clause no.	Page no.	Clause	Query	Bank Response

Place: _____

Date: _____

Signature: _____

Name & Designation: _____

Business Address: _____

ANNEXURE N: Certificate of Waiver for MSE firms

(In Letter head of Chartered Accountant)

Date:

TO WHOMSOEVER IT MAY CONCERN

This is to certify that M/s. _____, having registered office at _____. Further we certify that the Company is classified under Micro and Small Enterprise (MSE) as per MSME Act 2006 and subsequent government notifications.

We have checked the books of the accounts of the company and certify that the above information is true and correct.

Chartered Accountant Firm Name:

Signature: _____

Name: _____

Reg. No: _____

VID No: _____

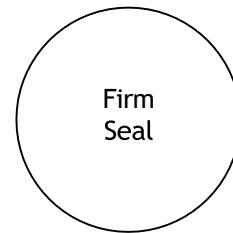

INDEMNITY BOND

(On Non-Judicial Stamp of adequate value)

KNOW all men by these presents that We M/s _____do hereby execute Indemnity Bond in favour of the Union Bank of India on this ____day of _____2026.

WHEREAS Union Bank of India, (address of the office) Union Bank Bhavan, 239, Central Office, Nariman point, Mumbai, have empanelled M/s _____(OEM supplier) for supply & installation of Physical Security Product's in branches on pan India basis.

THIS DEED WITNESS AS FOLLOWS:

We M/s _____ hereby do Indemnify and save harmless Union Bank of India, against

1. any losses and liability (including but not limited to liabilities, judgments, damages, losses, claims, costs and expenses, including attorney's fees and expenses) that may be occurring due to, arising from or relating to:
 - a) a breach, non -performance or inadequate performance by the OEM vendor of any of the terms, conditions, covenants, representations, undertakings, obligations or warranties under this RFP; or
 - b) the acts, errors, representations, misrepresentations, willful misconduct or negligence of the vendor, its employees in performance of its obligations under this RFP; or
 - c) any deficiency in the services of the vendor; or
 - d) Violation of any applicable laws by the OEM vendor, its agents, employee's representatives etc.; or damage caused to bank's property/premises during transportation and installation which is also liable to be recovered from payment of bills.
2. In the event of the OEM vendor not fulfilling its obligations under this clause within the period specified in the notice issued by Union Bank of India, Bank has right to recover the amounts due to it under this provision from any amount payable to the OEM vendor under this project.
3. The indemnities under this clause are in addition to and without prejudice to the indemnities given elsewhere in this agreement.

In witness whereof the parties has set their hand on this ____day of _____2026.

Signed and delivered by the

Name and address
aforesaid _____

2.
(OEM)

In the presence of witnesses:

1.

ANNEXURE P:

Undertaking for Testing

We,, hereby undertake to have the
..... tested in a BIS-accredited
laboratory as per the testing procedures specified in the relevant Indian Standard
(IS) referenced in this RFP.

Place:

Date:

Signature:

Name & Designation:

Business Address:
